

DATASHEET

Type: **MEMORY**
Name: Wall light
ID: US879
Designed by: Boris Klimek



Download

Description

The Memory collection awakens the imagination and beckons back to a carefree childhood. The wall and ceiling versions in different sizes, the wide range of color options, and a selection of finishes give this lighting experience a large degree of versatility.

Tech. description

The light consists of a metal ceiling mount with E26 light source socket and a glass shade with bayonet system. The E26 socket has an integrated switch for manual control.



Colours options: https://brokis.sharepoint.com/:b/s/brokis_sp/EXc__7y1_0VGkMWps_b7krgBrhFJ_qijQnQQdMrUn-OiVg

CONSTRUCTION SPECIFICATION

Weight: 9.26 lb
Construction material: glass, metal
Cord length [in]: -
Mounting: Wall
Environment: Dry

DIMENSIONS [in]

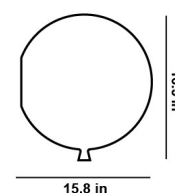

ELECTRICAL SPECIFICATION

Input voltage [V]: 120 V
Frequency [Hz]: 60 Hz
Max. power [W]: 7 W
Coverage IP: 20
Socket: E26
Light source: -

CERTIFICATIONS



BROKIS S.R.O.
ŠPANILOVA 1315/25
163 00 PRAHA 6 - ŘEPY
CZECH REPUBLIC

ORG ID 64940799
VAT ID CZ64940799
C 42174 MĚSTSKÝ SOUD
V PRAZE

TEL +420 567 211 517
TECHNICAL@BROKIS.CZ
INFO@BROKIS.CZ
WWW.BROKIS.CZ

2022_11
PAGE 1



INNER FIXTURE

Dimensions O x w [in]	4.6 x 3.8
Weight [lb]	0,44
Material	metal

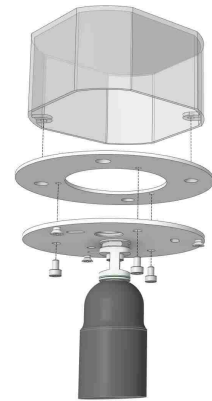

Drawing

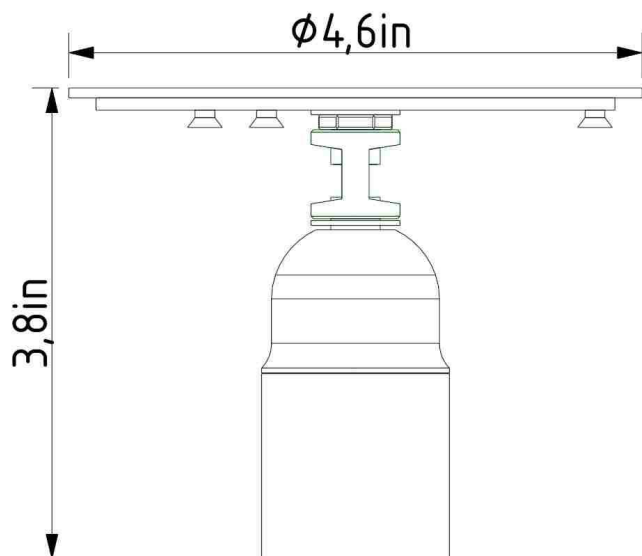

Hole placement

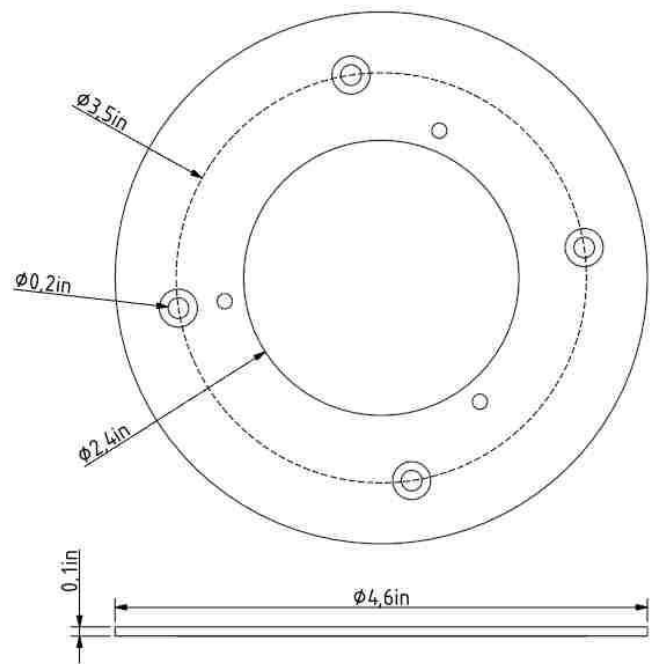

DATASHEET

Type: **MEMORY**
Name: Wall light
ID: US880
Designed by: Boris Klimek



Download

Description

The Memory collection awakens the imagination and beckons back to a carefree childhood. The wall and ceiling versions in different sizes, the wide range of color options, and a selection of finishes give this lighting experience a large degree of versatility.

Tech. description

The light consists of a metal ceiling mount with E26 light source socket and a glass shade with bayonet system. The E26 socket has an integrated switch for manual control.



Colours options: https://brokis.sharepoint.com/:b/s/brokis_sp/EQ09j03_-KtHiR6fiWD6mD4B9wu-O1htJkCp31MJoMi4bw

CONSTRUCTION SPECIFICATION

Weight: 5.73 lb
Construction material: glass, metal
Cord length [in]: -
Mounting: Wall
Environment: Dry

DIMENSIONS [in]

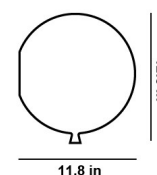

ELECTRICAL SPECIFICATION

Input voltage [V]: 120 V
Frequency [Hz]: 60 Hz
Max. power [W]: 7 W
Coverage IP: 20
Socket: E26
Light source: -

CERTIFICATIONS



BROKIS S.R.O.
ŠPANIĚLOVA 1315/25
163 00 PRAHA 6 - ŘEPY
CZECH REPUBLIC

ORG ID 64940799
VAT ID CZ64940799
C 42174 MĚSTSKÝ SOUD
V PRAZE

TEL +420 567 211 517
TECHNICAL@BROKIS.CZ
INFO@BROKIS.CZ
WWW.BROKIS.CZ

2022_11
PAGE 1



INNER FIXTURE

Dimensions O x w [in]	4.6 x 3.8
Weight [lb]	0,44
Material	metal

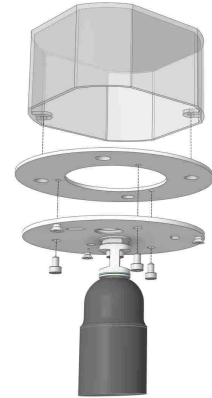

Drawing

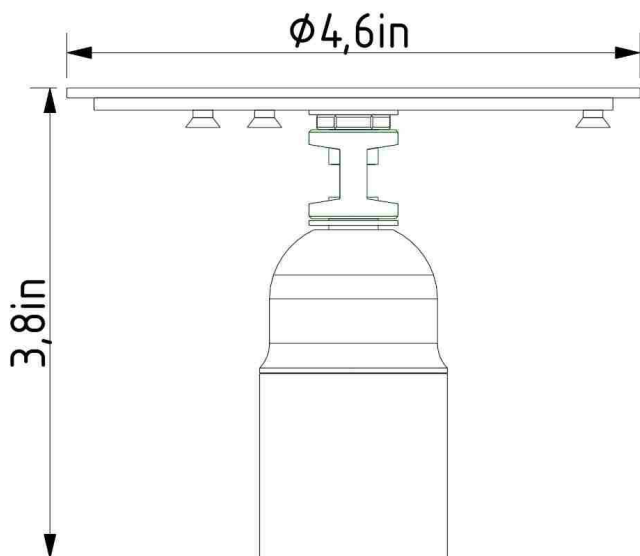

Hole placement

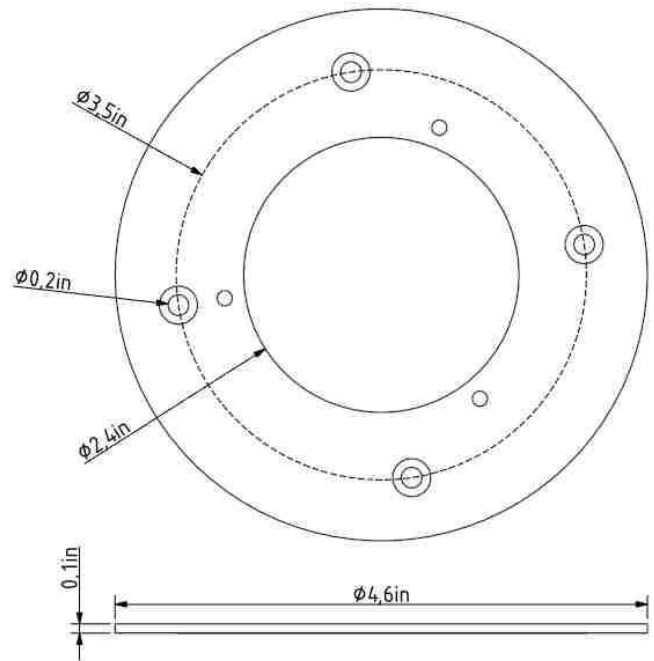

DATASHEET

Type: **MEMORY**
Name: Wall light
ID: US881
Designed by: Boris Klimek



Download

Description

The Memory collection awakens the imagination and beckons back to a carefree childhood. The wall and ceiling versions in different sizes, the wide range of color options, and a selection of finishes give this lighting experience a large degree of versatility.

Tech. description

The light consists of a metal ceiling mount with E26 light source socket and a glass shade with bayonet system. The E26 socket has an integrated switch for manual control.



Colours options: https://brokis.sharepoint.com/:b/s/brokis_sp/EZ00vzDZMCBApt63xHPTTL8Bg4kucugpAC93UZMCTcymgw

CONSTRUCTION SPECIFICATION

Weight: 4.74 lb
Construction material: glass, metal
Cord length [in]: -
Mounting: Wall
Environment: Dry

DIMENSIONS [in]

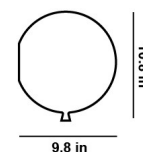

ELECTRICAL SPECIFICATION

Input voltage [V]: 120 V
Frequency [Hz]: 60 Hz
Max. power [W]: 7 W
Coverage IP: 20
Socket: E26
Light source: -

CERTIFICATIONS



BROKIS S.R.O.
ŠPANILOVA 1315/25
163 00 PRAHA 6 - ŘEPY
CZECH REPUBLIC

ORG ID 64940799
VAT ID CZ64940799
C 42174 MĚSTSKÝ SOUD
V PRAZE

TEL +420 567 211 517
TECHNICAL@BROKIS.CZ
INFO@BROKIS.CZ
WWW.BROKIS.CZ

2022_11
PAGE 1



INNER FIXTURE

Dimensions O x w [in] 4.6 x 3.8
Weight [lb] 0,44
Material metal

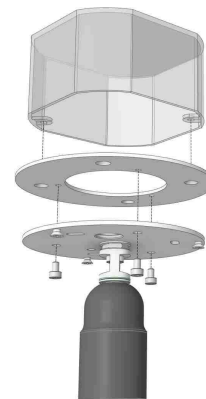

Drawing

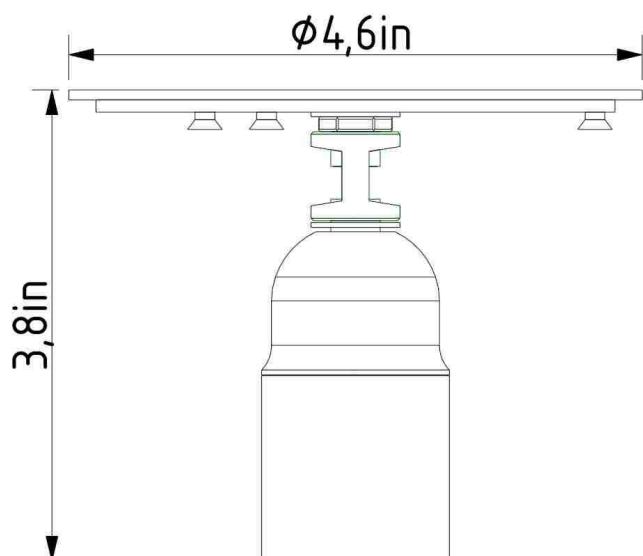

Hole placement

