

TECHNICAL SPECIFICATION

Catalano bench

OSCAR TUSQUETS AND LLUÍS CLOTET
1974

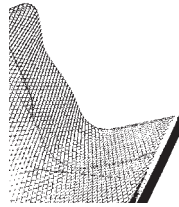

COMPONENTS, MATERIALS and FINISHES:

SEAT with steel tubular chassis of Ø18x2mm, recovered with a deployé steel sheet. Seat in modules of 1m length.

LEGS in tubular steel Ø25x2mm.

LEGS TO HANG

LEGS TO BUILD IN -Simple or Double-

FREE-STANDING LEGS (OR TO BE SCREWED) -Simple or Double-

ARMS in steel fixed by screws (optional).

Stainless steel **SCREWS**.

The wall **SECURING SCREWS** -bench to hang- and to the floor -free-standing bench-, are not supplied by Bd.

*Legs, seats and arms are hot-dip galvanized optionally painted in Grey Ref. 7035 texturized Silver.

DIMENSIONS and WEIGHTS:

CATALANO BENCH

-Bench to hang: 1000 x 760 x H.900mm

The placement of the screws for assembling to the wall: Ø8'5mm

-Simple bench to build in: 1000 x 755 x H.900mm

-Double bench to build in: 1000 x 1523 x H.900mm

-Free-standing simple bench: 1000 x 755 x H.900mm

-Free-standing double bench: 1000 x 1523 x H.900mm

The placement of the screws for assembling to the floor: Ø12mm

PARTS

-Seat: 14'5Kg

-Leg to hang: 2'5 Kg

-Simple leg to build in: 3Kg

-Double leg to build in: 3'5Kg

-Free-standing simple leg: 2'5Kg

-Free-standing double leg: 4Kg

PACKAGING:

The benches will be supplied unassembled.

BENCH TO HANG

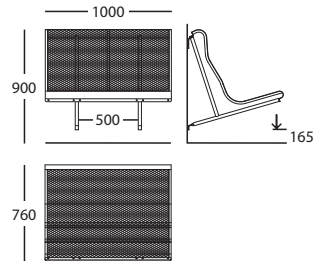

BENCH TO BUILD IN

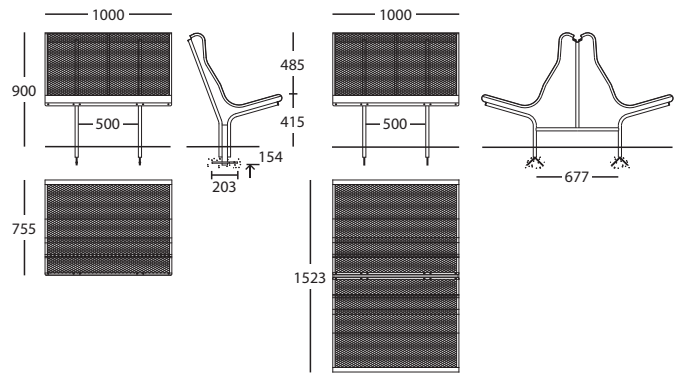

FREE-STANDING (OR TO BE SCREWED)

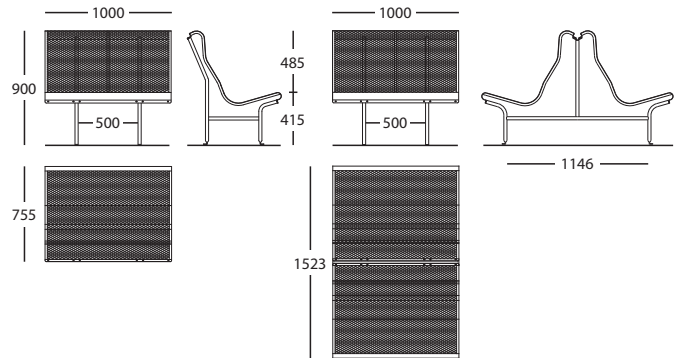

OPTIONAL ARMRESTS

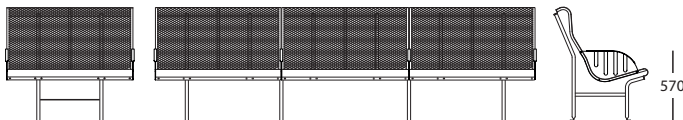

* Arms can be placed on both sides and between modules every 1 meter.

CATALANO BENCH CONTINUOUSLY

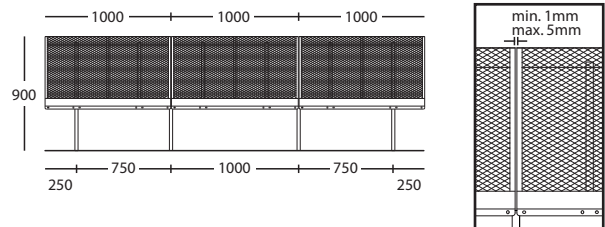

MEASUREMENTS IN MM



Bd Barcelona design

Ramon Turró, 126 / 08005 Barcelona

Tel +34 93 458 69 09 / Fax +34 93 207 36 97

bd@bdbarcelona.com / www.bdbarcelona.com

Technical department

Carretera Capellades / km 22,750

Narcís Monturiol, 7 / Pol. Ind Sesroviros

Sant Esteve de Sesroviros / 08635 Barcelona

Tel +34 93 771 30 51

FICHA TÉCNICA

Banco Catalano

OSCAR TUSQUETS Y LLUÍS CLOTET
1974

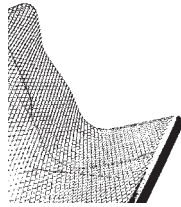

COMPONENTES, MATERIALES y ACABADOS:

ASIENTO formado por un chasis en tubo de acero de Ø18x2mm, recubierto con una chapa de acero deployé.

Asiento en módulos de 1m de longitud.

PATAS en tubo de acero de Ø25x2mm.

PATAS PARA COLGAR

PATAS PARA EMPOTRAR -Simple o Doble-

PATAS PARA APOYAR (O ATORNILLAR) -Simple o Doble-

BRAZOS en acero fijados mediante tornillería (opcionales).

TORNILLERÍA en acero inoxidable.

Los **TORNILLOS DE SUJECIÓN** a pared -banco para colgar- y al suelo -banco para apoyar-, no son suministrados por Bd.

* Patas, asientos y brazos de acero galvanizado en caliente con la posibilidad de pintar en color Gris Ref.7035 Texturado metalizado.

DIMENSIONES y PESOS:

BANCO CATALANO

-Banco para colgar: 1000 x 760 x H.900mm

Alojamiento del tornillo para el banco de colgar: Ø8'5mm

-Banco para empotrar simple: 1000 x 755 x H.900mm

-Banco para empotrar doble: 1000 x 1523 x H.900mm

-Banco para apoyar simple: 1000 x 755 x H.900mm

-Banco para apoyar doble: 1000 x 1523 x H.900mm

Alojamiento del tornillo para el banco de apoyar: Ø12mm

DESPIECE

-Asiento: 14'5Kg

-Pata para colgar: 2'5 Kg

-Pata simple para empotrar: 3Kg

-Pata doble para empotrar: 3'5Kg

-Pata simple para apoyar: 2'5Kg

-Pata doble para apoyar: 4Kg

EMBALAJE:

Los bancos se suministran desmontados.

BANCO PARA COLGAR

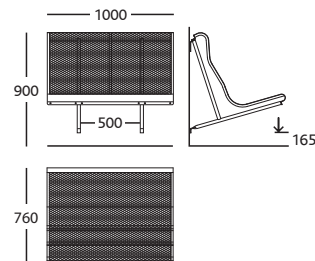

BANCO PARA EMPOTRAR

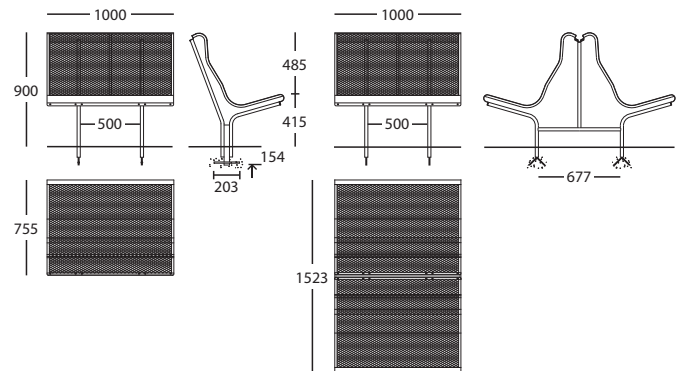

BANCO PARA APOYAR (O ATORNILLAR)

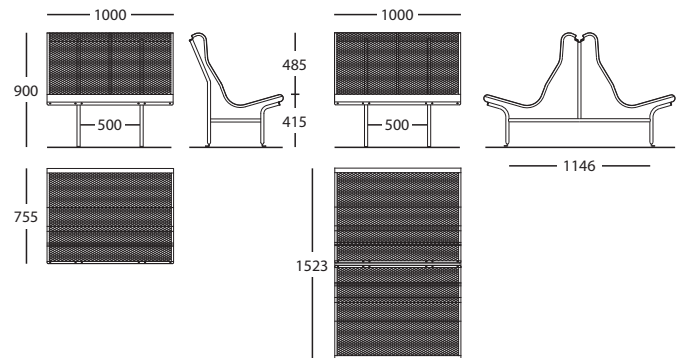

BRAZOS OPCIONALES

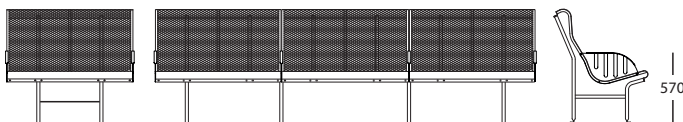

* Arms can be placed on both sides and between modules every 1 meter.

BANCO CATALANO EN CONTINUO

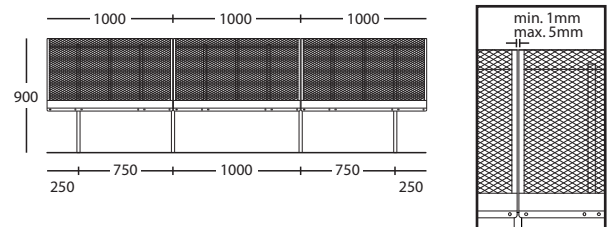

MEDIDAS EN MM



Bd Barcelona design

Ramon Turró, 126 / 08005 Barcelona

Tel +34 93 458 69 09 / Fax +34 93 207 36 97

bd@bdbarcelona.com / www.bdbarcelona.com

Technical department

Carretera Capellades / km 22,750

Narcís Monturiol, 7 / Pol. Ind Sesrovires

Sant Esteve de Sesrovires / 08635 Barcelona

Tel +34 93 771 30 51