

TECHNICAL SPECIFICATION

Cajones Lamp

Dalí Series
SALVADOR DALÍ
1937



COMPONENTS, MATERIALS AND FINISHES:

Structure sculpted from lime wood bleached and varnished with one coat of primer and two coats of semi-matte nitrocellulosic lacquer. The structure is formed using a base in which 5 moveable drawers appear along with a crutch above the area where the electrical portion rests. The two pieces stay united from top to bottom through a rifled M10 stud.

Lampshade made in a steel structure, coated with RAL 9010 epoxy paint. The fabric used as a light diffuser is beige coloured lingerie satin. Hand made.

ELECTRICAL EQUIPMENT:

Nominal voltage:	230W
Nominal frequency:	50Hz
Isolation class:	CLASS I
IP:	20
Number of lamps:	1
Power:	9W
Lamp type:	LED
Lamp holder type:	E-27

This light is conceived to be set up on a normally inflammable surface. It has been tested according to UNE-EN 60598-2-1:93 and UNE-EN 60598-1:01 and has achieved CE marking. Electrical installation with earth plate for an incandescent light bulb of 100W maximum. Golden chain switch in the socket. Support leg in solid faded beech. This is varnished with a coat or pore cover and two coats of semi-matt nitrocellulose lacquer. The leg is supported against the structure with a wooden peg. Counterweight of shot wrapped in a white cotton sewn bag. This is placed inside the structure. This is placed inside the structure.

AUTHENTICITY DETAILS:

Identification plaque (5x1cm) of shiny polished brass with adhesive on one side in which appears engraved: "Lámpara Cajones, 1937, Salvador Dalí, Bd Ediciones de Diseño" and the serial number of the product.

The plaque is situated in the inferior part of the structure.

Transparent adhesive (5 x 1cm) c with text in black, in which appear the words: "© Salvador Dalí, Fundación Gala-Salvador Dalí, Barcelona 2003 (current edition year).

The adhesive is situated on the lamp holder.

DIMENSIONS:

Lamp: 300x300xh.867mm;
Lampshade: 300x300xh.300mm.

WEIGHT:

Lamp: 4Kg;
Lamp with packaging: 10Kg.

PACKAGING:

The lamp will be delivered properly packed and in a box of triple-layered cardboard with pinewood-reinforced lateral sides. The lampshade comes in a properly wrapped separate box.

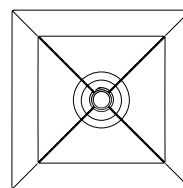
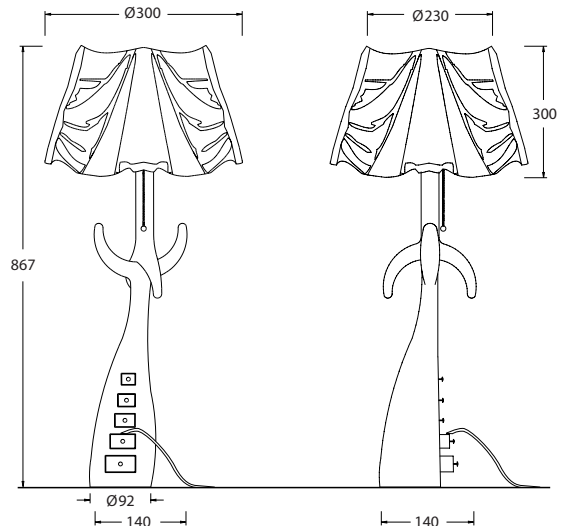

MAINTENANCE:

Dyed Lime Wood Finish: Apply a natural wax product with a cotton cloth or use only a dry cotton cloth. Do not use abrasive or solvent products.

Lampshade Chiffon Finish – Cotton: Clean surface applying a dry cotton cloth. Do not use abrasive or solvent products.

USE AND PLACEMENT:

1. The lamp supplied is "apt for indoor placement".
2. The lamp should be correctly used with an alternating current feed.
3. If the lamp has a flexible cable or the lead is damaged, this should be exclusively substituted by the manufacturer or by their appointed technical support service. An equivalent qualified person may also repair the lamp with the objective of avoiding any damage.

MEASUREMENTS IN MM



Bd Barcelona design
Ramon Turró, 126 / 08005 Barcelona
Tel +34 93 458 69 09 / Fax +34 93 207 36 97
bd@bdbarcelona.com / www.bdbarcelona.com

Export office
Carretera Capellades / km 22,750
Narcís Monturiol, 7 / Pol. Ind Sesrovires
Sant Esteve de Sesrovires / 08635 Barcelona
Tel +34 93 771 30 51 / Fax +34 93 771 32 32
comercial@bdbarcelona.com / www.bdbarcelona.com