

TECHNICAL SPECIFICATION

Table B + Big Table B

KONSTANTIN GRČIĆ
2009



COMPONENTS AND MATERIALS

The **table top** is composed of four AL 6060 extruded aluminium slats (and five slats for the Big Table B model). The binding profile is in AL 6082 extruded aluminium.

Joint pieces are in steel with white zinc coating.

Screws are in stainless steel.

The **fixing brackets** for the concrete base leg are in a powder coated silver coloured epoxy polyester steel.

Architectural concrete base in grey.

The **wooden legs** are made of ash, stained oak and varnished.

The **stainless steel rod legs** option are electro polished.

FINISHES

The slats are in anodised silver and scotch polished. A laminate of 0.9 mm on the upper surface of the slats can be applied in simil oak, white and or a black finish.

LIMITATIONS

The Big Table B models only come with wooden legs.

DIMENSIONS	WEIGHT	Table B	Big Table B
180 x 120 x 73 cm 70 ¾" x 47 ¼" x 29"	Sobre 180	43Kg 94,8 lbs	-
240 x 120 x 73 cm 94 ½" x 47 ¼" x 29"	Sobre 240	57Kg 125,6 lbs	-
300 x 120/150 x 73 cm 118" x 47 ¼"/59" x 29"	Sobre 300	72Kg 158,7 lbs	90Kg 198,4 lbs
360 x 120/150 x 73 cm 141 ¾" x 47 ¼"/59" x 29"	Sobre 360	86Kg 189,6 lbs	107Kg 235,9 lbs
400 x 120/150 x 73 cm 157 ½" x 47 ¼"/59" x 29"	Sobre 420	100Kg 220,5 lbs	125Kg 275,5 lbs
500 x 120/150 x 73 cm 196¾" x 47 ¼"/59" x 29"	Sobre 500	120Kg 264,5 lbs	150Kg 330,7 lbs

Concrete base: 60kg / 132,3 lbs

Wooden legs: 10Kg/unid / 20 lbs/u

Stainless steel rod legs: 6,5Kg/unid / 14,3 lbs/u

(Approximate weights)

CLEANING AND MAINTENANCE

To clean the tops with an anodised silver finish, only apply a damp organic cleaning cloth using only water and a neutral pH soap, or alcohol for burning (methanol 95). To clean the tables with a laminated finish, only use a glass cleaner which is alcohol free and a dampened (with water) organic cloth. Do not use aggressive products (with a low pH), solvents or any of other agents containing these derivatives.

TESTS

This table satisfactorily meets standards EN 15372:2008 and UNE EN 1730:2000.

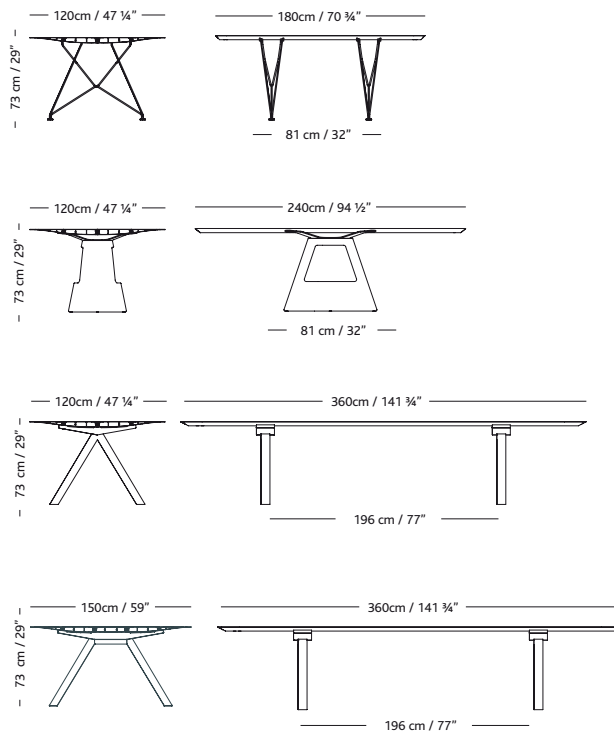

INTEGRATED CABLE MANAGEMENT within the table top, comes with an anodised aluminium sliding open and closing system. The kit includes:

- A box with a sliding open and closing system in anodised aluminium
- A connection terminal made up of:
Socket type Schuko M – 35° ground connection RJ45 CAT6 BTR connectors VGA + stereo BCM
- Premium Snake Cable in silver
- Power cord

Limitations

Only available with wooden legs and stainless steel legs.

Width 120 cm / 47 1/4"

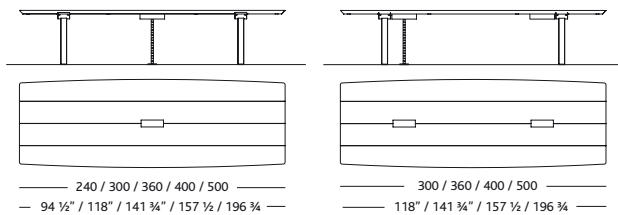

Width 150 cm / 59"

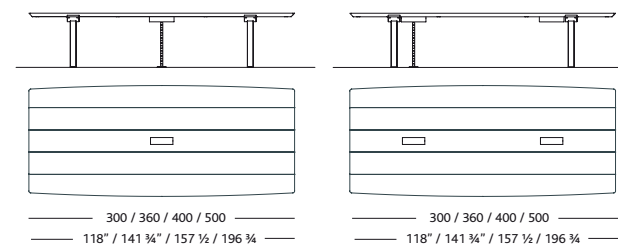

PATTERNS OF LAMINATED TOPS

For tables with laminated slats with a length of 180cm/70 3/4" to 360cm/141 3/4" are whole. For laminated tables measuring 400cm/157 1/2" and 500cm/196 3/4", please see diagrams of patterned tops. EN 1730:2000.

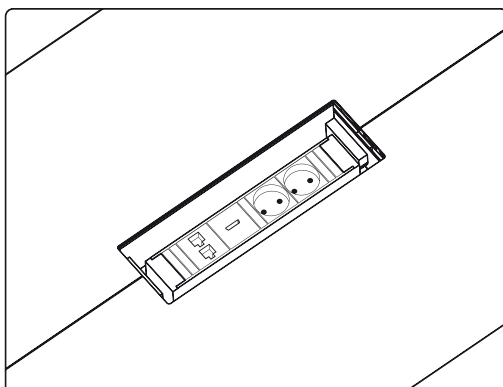
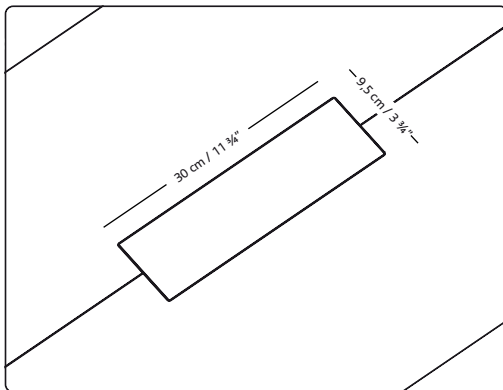
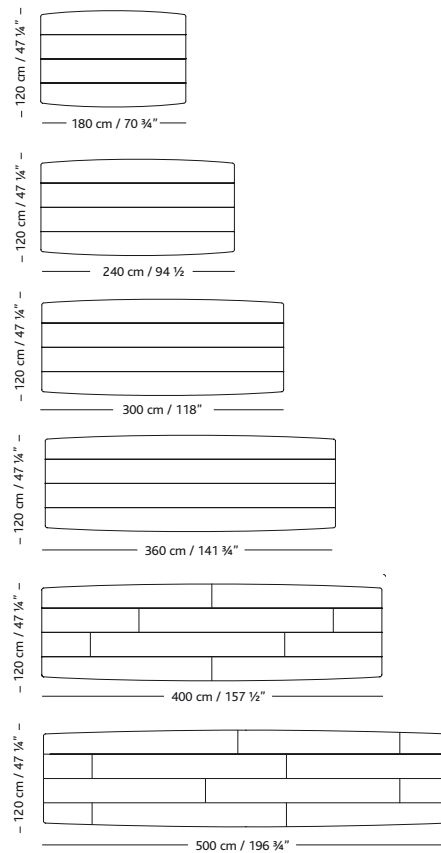

PACKAGING

The aluminium top is provided in a wooden crated box which is protected with celaire film, bubble wrap and a 6 cm foam on the inside. The concrete base and other legs are supplied in a cardboard box and pallet.

ENVELOPES	TABLE B		BIG TABLE B	
	DIMENSIONS	WEIGHTS	DIMENSIONS	WEIGHTS
180	194 x 21 x h141 cm	83 kg	-	-
240	254 x 21 x h141 cm	107 kg	-	-
300	314 x 21 x h141 cm	132 kg	314 x 21 x h171 cm	155 kg
360	374 x 21 x h141 cm	159 kg	374 x 21 x h171 cm	187 kg
400	414 x 22 x h141 cm	195 kg	414 x 22 x h171 cm	230 kg
500	514 x 22 x h141 cm	235 kg	514 x 22 x h171 cm	275 kg

ENVELOPES	TABLE B		BIG TABLE B	
	DIMENSIONS	WEIGHTS	DIMENSIONS	WEIGHTS
180	76 ½" x 8 ¼" x h55 ½"	183 lbs	-	-
240	100" x 8 ¼" x h55 ½"	236 lbs	-	-
300	118" x 8 ¼" x h55 ½"	291 lbs	118" x 8 ¼" x h67 ½"	342 lbs
360	147 ¼" x 8 ¼" x h55 ½"	350 lbs	147 ¼" x 8 ¼" x h67 ½"	412 lbs
400	162" x 8 ½" x h55 ½"	430 lbs	162" x 8 ½" x h67 ½"	507 lbs
500	202 ½" x 8 ½" x h55 ½"	518 lbs	202 ½" x 8 ½" x h67 ½"	606 lbs

LEGS	TABLE B		BIG TABLE B	
	DIMENSIONS	WEIGHTS	DIMENSIONS	WEIGHTS
CONCRETE	120 x 80 x h85 cm	83 kg	-	-
WOOD	98 x 40 x h91 cm	22 kg	125 x 46 x h85 cm	36 kg
STEEL ROD	98 x 40 x h91 cm	18 kg	-	-

LEGS	TABLE B		BIG TABLE B	
	DIMENSIONS	WEIGHTS	DIMENSIONS	WEIGHTS
CONCRETE	47 ¼" x 31 ½" x h33 ½"	183 lbs	-	-
WOOD	38 ½" x 15 ¾" x h35 ¾"	49 lbs	49 ¼" x 18" x h33 ½"	79 lbs
STEEL ROD	38 ½" x 15 ¾" x h35 ¾"	40 lbs	-	-



BD Barcelona Design

Ramon Turró, 126 / 08005 Barcelona
Tel +34 93 458 69 09 / Fax +34 93 207 36 97
bd@bdbarcelona.com / www.bdbarcelona.com

Oficina Técnica

Carretera Capellades / km 22,750
Narcís Monturiol, 7 / Pol. Ind Sesrovires
Sant Esteve de Sesrovires / 08635 Barcelona
Tel +34 93 771 30 51 / Fax +34 93 771 32 32