

marset
news
2016/17

www.marset.com

Factory & Headquarters

Alfonso XII 429-431
08918 Badalona (Spain)
T +34 934 602 067
F +34 934 601 089
info@marset.com

Barcelona Showroom

Santaló 56 Interior
08021 Barcelona (Spain)
T +34 932 005 726
press@marset.com

Marset USA Inc.

20 West 22nd Street–Suite 903
New York, NY 10010
T +1 646 727 4250
F +1 646 304 6959
marsetusa@marset.com

Index

A

118 Aura

B

84 Bicoca

C

112 Concentric S, M, L

66 Copérnica M

46 Copérnica P, P190

D

24 Djembé

140 Djembé C

F

94 FollowMe Plus

J

20 Jaima

156 Jaima IP65

L

30 LED-Ginger 20, 20x3

136 LED-Ginger 20A

130 LED-Ginger C, C2, C3

102 LED-Ginger 20M

N

124 N°8

P

14 Piola

8 Pu-erh

40 Pleat Box LED

S

36 Soho

170 Soho IP65

148 Sun

T

74 Theia M

56 Theia P

8 – 44
Pendant

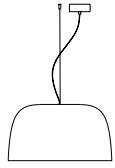

24
Djembé



30
LED-Ginger



14
Piola

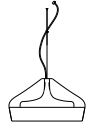

40
Pleat Box

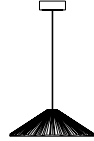

8
Pu-erh



36
Soho

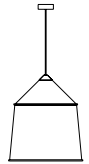

20
Jaima

46 – 64
Floor

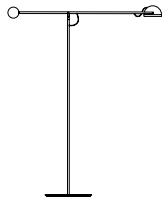

46
Copérnica



56
Theia

66 – 82
Table

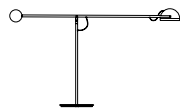

66
Copérnica



74
Theia

84 – 110
Portable



84
Bicoca



94
FollowMe Plus



102
LED-Ginger

112 – 138
Wall



118
Aura

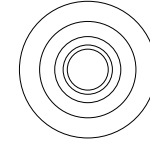

112
Concentric



136
LED-Ginger

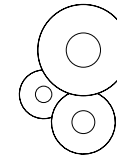

130
LED-Ginger

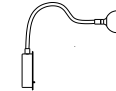

124
Nº8

140 – 154
Ceiling

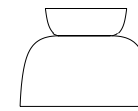

140
Djembé



148
Sun

156 – 176
Outdoor

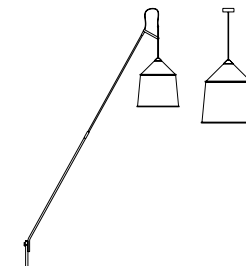

156
Jaima

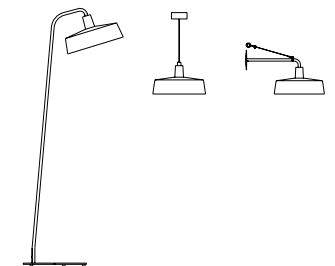

170
Soho

Pendant

Pu-erh

The distinction of the new Pu-erh collection lies in its use of ceramics as material to yield a lamp with a delicate, fabric-like effect. Designer and ceramist Xavier Mañosa has created a texture, evoking pleated silk, which is then applied to a conical shade, casting a wide and beautiful ray of illumination.

The Pu-erh begins with a rough sketch, drawn by the hand of its designer. This sketch, with all its ridges and grooves, is applied directly to the ceramic mold, yielding a lamp whose irregular variations supply a raw, natural effect. This underlies the collection's most essential aspect: the simplicity of its artisanal process. The craftsman barely intervenes, letting the lamp take shape naturally within the mold. The Pu-erh is arresting in its simplicity and innovative in the transparency of its process.

This new collection of suspension lamps is available in three sizes – 8, 12 and 16 inches – and a wide range of muted colors that allow one to appreciate the texture of the ceramic: black, white, blue, burgundy and pink. Dancing off the beautifully rippled underside of the shade, Pu-erh's light is warm, pleasant, and playful.



Ceramic diffuser with the inner part in white or gold enamel.

- White-White
- White-Gold
- Pink-White
- Pink-Gold
- Burgundy-White
- Burgundy-Gold
- Blue-White
- Blue-Gold
- Black-White
- Black-Gold

Pu-erh 21
LED SMD 4W 350mA 2700K 700lm (included)

Pu-erh 32 Dimmable
LED SMD 7,8W 700mA 2700K 1066lm (included)

Pu-erh 42 Dimmable
LED SMD 7,8W 700mA 2700K 1066lm (included)

Pu-erh 21

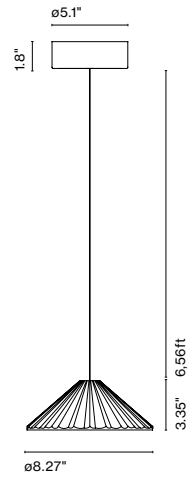

Pu-erh 32

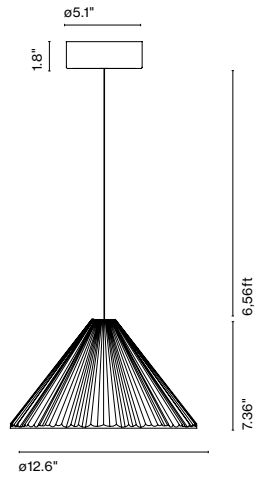

Pu-erh 42

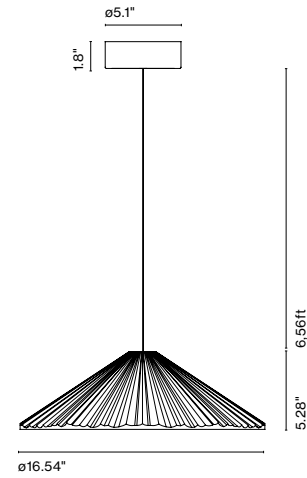

Dry locations only

Black electrical cord







Piola

How does one design a light that translates the playfulness of an endlessly spiraling ribbon? The Piola collection is about imitating this fluidity of infinite movement, in search of a balance between the diffusion of light and the creation of shadows.

A central metal column holds more than 16 feet of spiraling, laminated band, enveloping, protecting, and sifting the light for beauty and comfort. Several different types of light coexist here: direct downward light, indirect reflected light, and a light that sneaks between the edges of the spiral, illuminating the fixture itself with a warm, homey glow.

The fixture's spiraling form breaks with the monotony of cleanly ordered lines, offering a different face from every angle. At the same time, the central column provides a symmetry and solidity that supports and reinforces the visual movement of the screen.

The Piola is available in four colors, with the structure and screen always in the same color to lend the fixture cohesion and unity. In this way, by contrast, the quality of the light takes center stage.





Laminated band made of PVC and polyester which revolves around a central metallic column lacquered in the same color of the band. Inner structure in polycarbonate to hold the band to the axis.

- White
- Green
- Pink
- Graphite

Piola
LED SMD 11,7W 700mA 2700K 2040lm (included)

Piola

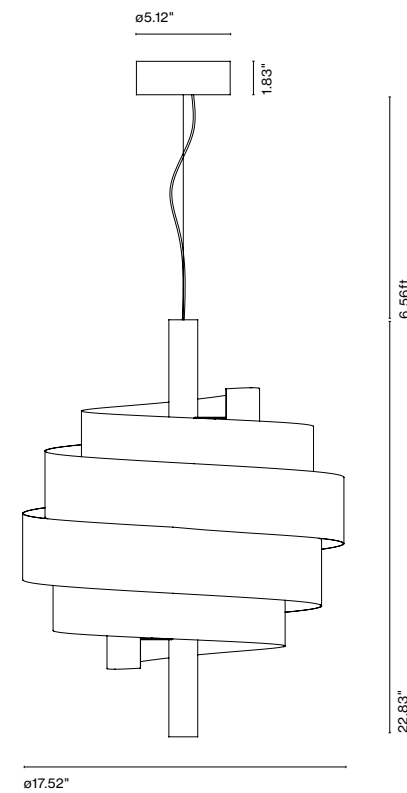

Dimmable

Dry locations only

Black electrical cord

Jaima

Through the language of textiles, Joan Gaspar has designed a light of flexible, ductile materials that sifts the light as readily as it moves with the wind. In the Jaima collection, the light is the shade and weaver of emotions.

This new collection takes its name from the Bedouin tents of North Africa, and is inspired by their varied fabrics and forms. The textile shade is available in three sizes and four different colors, with an off-white interior to optimize the quality of the downward light.





Shade made of textilene with the inner part always in white.

- Green
- Blue
- Beige
- Grey

Jaima 41

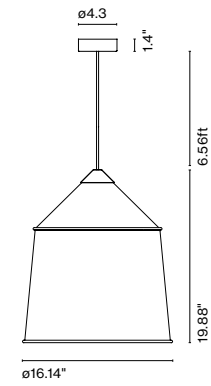

Jaima 52

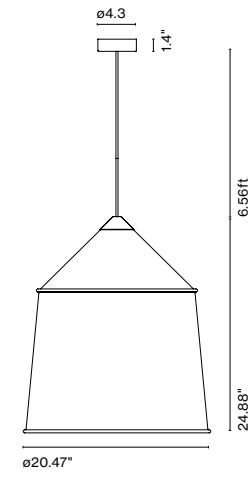

Jaima 71

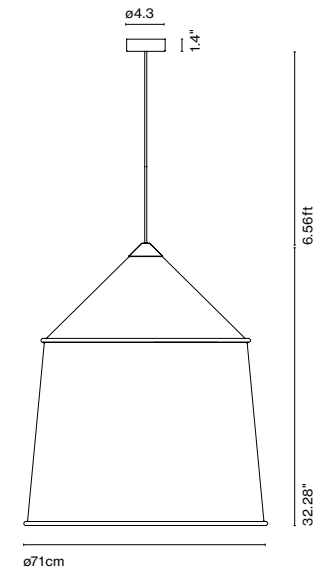

Shade finishes



Dimmable

Dry locations only

Black electrical cord

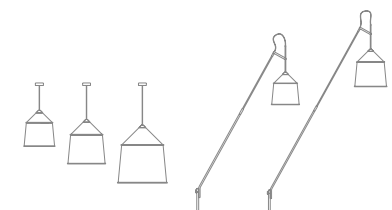

Range

Djembé

Like the echo of a drum, the Djembé collection is designed for repetition, creating musical compositions of light. A bell-shaped ceiling fixture with an exposed interior, Djembé is available in a two sizes with different heights and bright, airy colors that can be used individually or combined to create a brilliant statement piece.

Using a rotomolding technique allowed the designer, Joan Gaspar, to design a fixture with vastly different interiors and exteriors: its outside recalls the texture of a stone, giving off a perception of great weight, emphasized by its volume. In the spacious interior you'll find a smooth, white space perfect for the reflection of light. Djembé is a lamp designed for use in interior spaces that seeks to bring beauty and an unbeatable quality of light.



Shade made of bi-injected rotary moulded polyethylene: stone texture on the outer part and smooth satin white on the inner part of the fixture. Diffuser in lacquered grey aluminum.

- White
- Grey (RAL 7022)
- Red
- Sky blue

Djembé 42
LED SMD 11,7W 700mA 2700K 2040lm (included)

Djembé 65
LED SMD 20,8W 700mA 2700K 3023lm (included)

Djembé 42.13

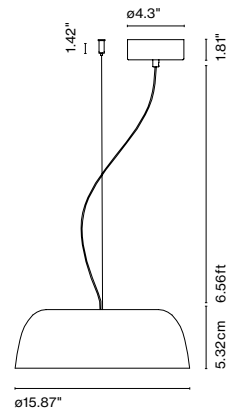

Djembé 42.21

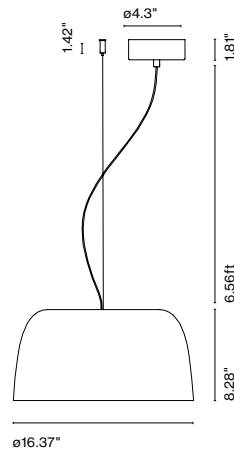

Djembé 42.28

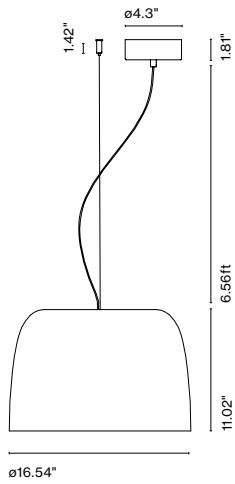

Djembé 65.23

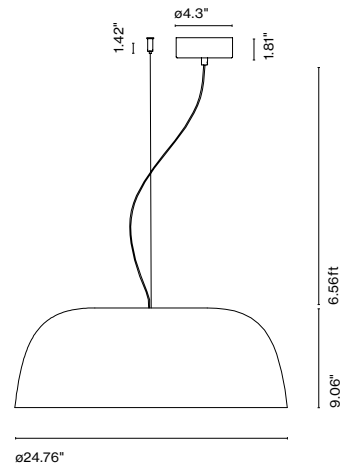

Djembé 65.35

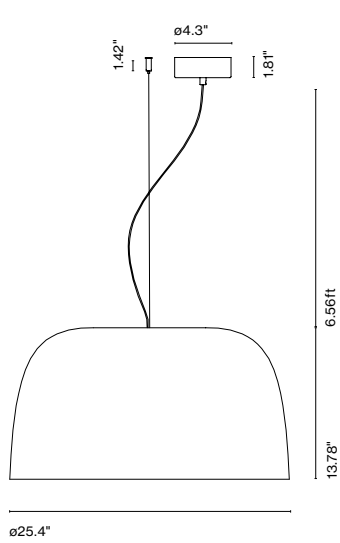

Djembé 65.45

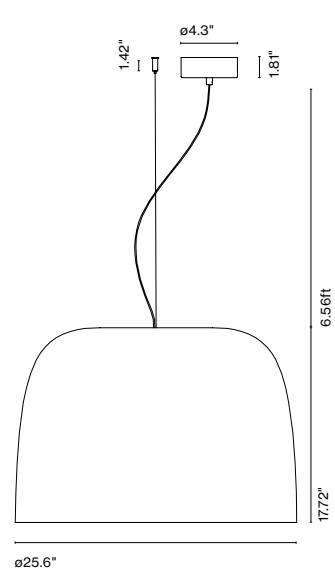

Pendant

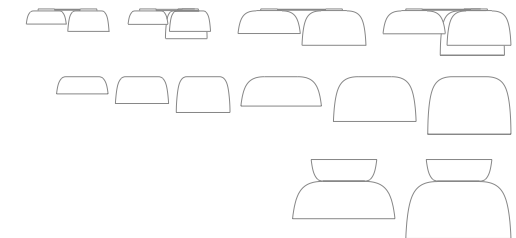

Dry locations only

Dimmable Black electrical cord

Range



LED-Ginger

Wood is a great ally of cozy lighting. It is a material that is hard to mold, a challenge that the LED-Ginger collection neatly resolves. The combination of sheets of wood, paper and resins pressed together under high pressure achieves a laminate that appears almost entirely flat, which discreetly lights up spaces with indirect light.

The LED-Ginger collection has been expanded over time to provide solutions to different lighting needs, and is available in pendant, table, wall, and floor lamp versions. This year, we are adding a new, smaller suspension lamp, a portable table lamp, another version of wall lamp with a movable arm, and three different sizes of flush-mount wall lamps. The latter boast extraordinary structural simplicity, and can be combined with each other to great effect.

The new suspension lamp with a smaller diameter (ø7.7") is ideal for areas that need a small point of light, and its wall version with an arm is perfect for lighting up the bedstead. Plus, in suspension form it comes in a group of three units.





Pendant

Pressed wood diffuser of 0.16 inches in natural oak or wenge. Injected and lacquered black metal matte aluminum dissipater.

- Oak-White
- Wenge-White
- Oak-Oak
- Wenge-Wenge

LED-Ginger 20

LED SMD 4W 350mA 2700K 546lm (included)

LED-Ginger 20x3

3x LED SMD 4W 350mA 2700K 546lm (included)

LED-Ginger 20



LED-Ginger 20x3

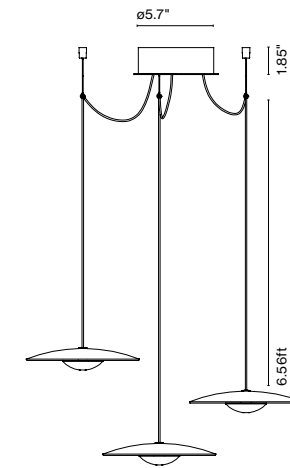

**Canopy accessory
LED-Ginger 20x3**

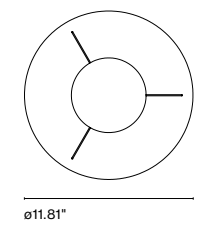

Black electrical cord
**Only LED-Ginger 20x3



Dimmable**

Dry locations only

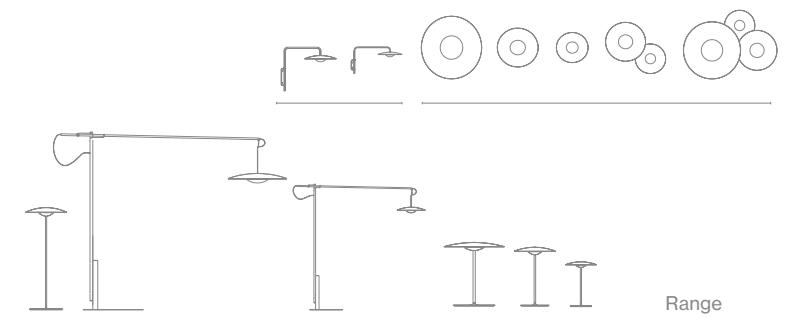

LED-Ginger – Joan Gaspar, 2016



Soho

Soho is presented as a statement, in recognition of the merits of the lamps traditionally used in markets, taverns and cafeterias. After studying different volumes, proportions and materials, new uses and lighting effects have emerged.

The use of rotation-moulded polyethylene allows us to easily offer this fixture in a wide range of sizes. Whereas before the Soho collection offered diameters of 22" and 44", now it's also available in a smaller size, measuring just 15". This new size is more appropriate for smaller spaces, and increases the overall versatility of this fixture. This new size is also available as a new outdoor floor lamp, thus completing the collection.

The existing color range—black, grey and translucent white—is now joined by two new tones: sand and sky blue.





Shade in rotary moulded polyethylene. Methacrylate opal diffuser.

- White
- Stone grey
- Black
- Sand
- Sky blue

Soho 38 LED
LED SMD 13.2W 700mA 2700K 1931lm (included)

Soho 38 LED

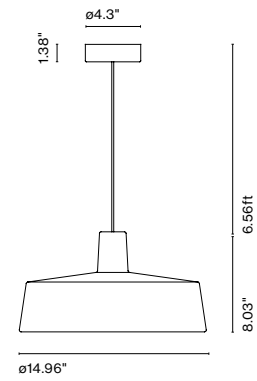

Black electrical cord

Dimmable
Dry locations only

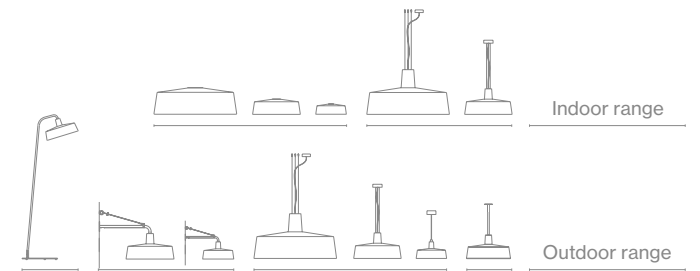

Pleat Box LED

The idea behind the Pleat Box is a sophisticated combination between a digitally designed crease in a piece of cloth and a silhouette that is applied to a ceramic base.

The ceramic shade is offered in white, brown, black, terracotta, and grey finishes, while the interior is available in brilliant white enamel, which enhances the light output, or 24k gold, which generates an extremely warm light.

The Pleat Box collection is now available with an integrated LED technology, which projects indirect light and prevents glare.





Ceramic shade with the inner part in brilliant white enamel or gold. Ceramic canopy.

- White-White
- White-Gold
- Grey-White
- Grey-Gold
- Terracotta-White
- Terracotta-Gold
- Black-White
- Black-Gold
- Brown-White
- Brown-Gold

Pleat Box 13 LED
LED SMD 4W 350mA 2700K 456lm (included)

Pleat Box 24 LED Dimmable
LED SMD 7,8W 700mA 2700K 1066lm (included)

Pleat Box 36 LED Dimmable
LED SMD 7,8W 700mA 2700K 1066lm (included)

Pleat Box 47 LED Dimmable
LED SMD 15,4W 700mA 2700K 2130lm (included)

Pleat Box 13 LED

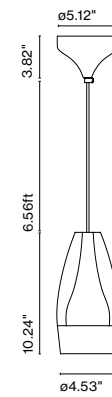

Pleat Box 24 LED

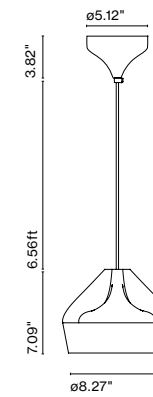

Pleat Box 36 LED

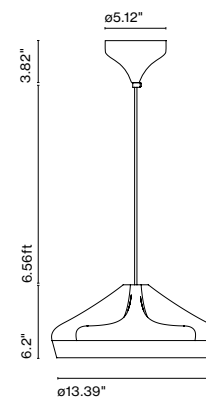

Pleat Box 47 LED

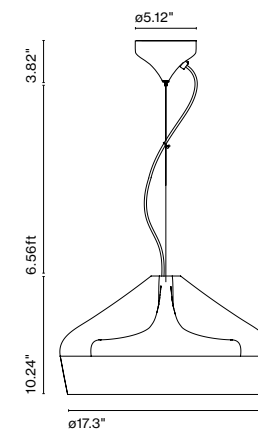

White fabric electrical cord and integrated LED disk in white whenever the inner part or the outer part of the lamp is white. If not, the fabric electrical cord and the integrated LED disk are black.



Floor

Copérnica

With no more than fingertips, one can achieve a feeling of weightlessness with the Copérnica lamp. As if levitating, it moves through space effortlessly, without friction or resistance.

Circles, semicircles, tubes, and bars of different diameters, materials, and weights... with the combination of these primary elements the Copérnica collection constructs geometric sculptures of light, establishing an intimate relationship with space and combining functionality with the beauty of pure lines.

The collection consists of desktop and standing versions that play with counterweights of mixed materials and density, such as steel and aluminum. This design allows one to move the lamp with great precision, providing a wide range of heights, distances, and adjustments to the beam of light to suite one's taste.

The upright version, a true statement piece, stands almost six feet in height and directly or indirectly illuminates the environment with its tilting head system.

Copérnica draws minimalist sculptures in space, as if it were a canvas, and the carefully selected colors add soft chromatic touches to the ensemble.





Structure in satin nickel or graphite with the base and counterweight in lacquered steel. Tilttable diffuser in aluminum. Built-in switch.

Copérnica P

- Satin Nickel-Golden-White
- Satin Nickel-Graphite-White
- Satin Nickel-Red-White
- Graphite-Golden-Black
- Graphite-Matt Chrome-Black
- Graphite-Red-Black

Copérnica P190

- Satin Nickel-White
- Graphite-Black

Copérnica P

LED SMD 4.6W 700mA 2700K CRI90 427lm (included)

Copérnica P190

LED SMD 25.9W 700mA 2700K CRI90 3380lm (included)

Copérnica P

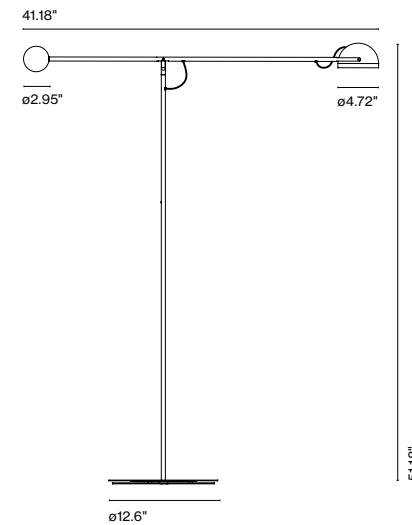

Copérnica P190



Dimmer*

Dry locations only

*3 positions dimmer
Black electrical cord







Floor



Copérnica – Ramírez i Carrillo, 2017



Theia

The Greek goddess Theia –mother of the sun, the moon and the dawn– lends her name to this lamp, whose design seeks to express the beauty of light and the fascination we feel for it. In Theia, the materials and shapes are merely the physical manifestations of the underlying concept: merging both light and shadow in a single piece.

Theia has two faces: to discover them, simply swivel the fixture around its central axis. It can be pointed towards you for use as a reading lamp, or towards an object or a wall, creating a subtle, indirect light that immediately warms the atmosphere. Because Theia's metal lampshade is totally opaque, this swivelling movement totally shifts the perception of the piece.

Theia's formal design is elementary and streamlined: two half-spheres, one placed horizontally and the other vertically, which intersect with each other. Just as in nature itself, these formal elements make it possible for the light from a source to be simultaneously projected, reflected, and absorbed by objects for our visual enjoyment.





Base and stem in lacquered iron. Dissipater in lacquered aluminum with built-in switch. Vertical semi-sphere made of lacquered spun metal, with the interior in white, and a transparent smoked shade in thermoformed methacrylate.

- White
- Black

Theia P
LED SMD 7,8W 700mA 2700K 1066lm (included)

Theia P

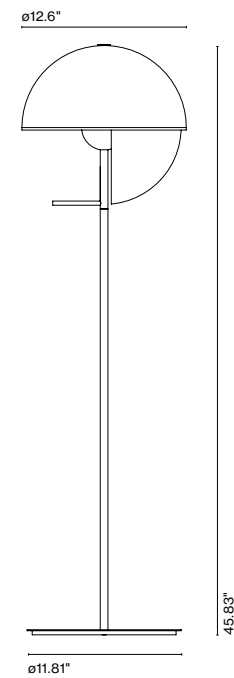

Black electrical cord

Dimmer
Dry locations only

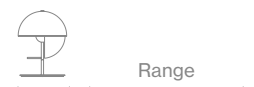





Table

Copérnica

With no more than fingertips, one can achieve a feeling of weightlessness with the Copérnica lamp. As if levitating, it moves through space effortlessly, without friction or resistance.

Circles, semicircles, tubes, and bars of different diameters, materials, and weights... with the combination of these primary elements the Copérnica collection constructs geometric sculptures of light, establishing an intimate relationship with space and combining functionality with the beauty of pure lines.

The collection consists of desktop and standing versions that play with counterweights of mixed materials and density, such as steel and aluminum. This design allows one to move the lamp with great precision, providing a wide range of heights, distances, and adjustments to the beam of light to suite one's taste.

The upright version, a true statement piece, stands almost two meters in height and directly or indirectly illuminates the environment with its tilting head system.

Copérnica draws minimalist sculptures in space, as if it were a canvas, and the carefully selected colors add soft chromatic touches to the ensemble.





**Structure in satin nickel or graphite with the base and counterweight in lacquered steel.
Tilttable diffuser in aluminum with a built-in switch.**

- Satin Nickel-Golden-White
- Satin Nickel-Graphite-White
- Satin Nickel-Red-White
- Graphite-Golden-Black
- Graphite-Matt Chrome-Black
- Graphite-Red-Black

Copernica M
LED SMD 4,6W 700mA 2700K CRI90 427lm
(included)

Copernica M

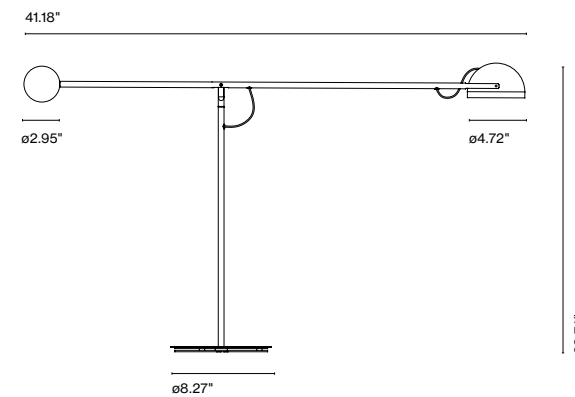

Black electrical cord
**3 positions dimmer

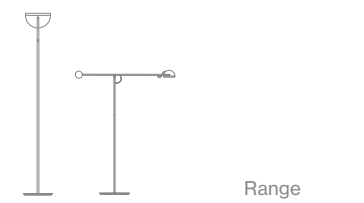





Theia

The Greek goddess Theia –mother of the sun, the moon and the dawn– lends her name to this lamp, whose design seeks to express the beauty of light and the fascination we feel for it. In Theia, the materials and shapes are merely the physical manifestations of the underlying concept: merging both light and shadow in a single piece.

Theia has two faces: to discover them, simply swivel the fixture around its central axis. It can be pointed towards you for use as a reading lamp, or towards an object or a wall, creating a subtle, indirect light that immediately warms the atmosphere. Because Theia's metal lampshade is totally opaque, this swivelling movement totally shifts the perception of the piece.

Theia's formal design is elementary and streamlined: two half-spheres, one placed horizontally and the other vertically, which intersect with each other. Just as in nature itself, these formal elements make it possible for the light from a source to be simultaneously projected, reflected, and absorbed by objects for our visual enjoyment.





Base and stem in lacquered iron. Dissipater in lacquered aluminum with built-in switch. Vertical semi-sphere made of lacquered spun metal, with the interior in white, and a transparent smoked shade in thermoformed methacrylate.

- White
- Black

Theia M
LED SMD 7,8W 700mA 2700K 1066lm (included)

Theia M

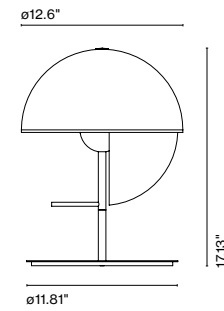

Black electrical cord

- cUL US
- Dimmer
- Dry locations only

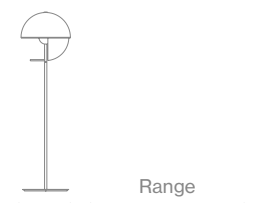





Portable

Bicocha

The Bicocha is born with the optimism of brightening life and accompanying the good times, wherever you go. This new colorful, lightweight portable lamp projects an intimate light that adds warmth to all your personal spaces.

Made of polycarbonate, Bicocha begins with an overlay of basic geometric figures, with a tiltable shade to direct the light. Three separate accessories increase the applicability and versatility of the lamp. A powerful magnet can be affixed to the bottom of the fixture, allowing you to place it to metal surfaces—even vertical walls—defying gravity. An armchair accessory drapes over armrests, sofa backs, or headboards, so that you can bring you Bicocha to all your personal reading spaces. And a metallic disc accessory hides discreetly beneath the tablecloth, securing your Bicocha to the table.

The wide range of shade colors provide an option for any taste and any space. Bicocha is small, manageable, versatile and autonomous.





Color polycarbonate and shade. Opal diffuser polycarbonate. Stainless steel and teflon joint.

- Off-white (RAL 9001)
- Anthracite (RAL 7026)
- Red wine (RAL 3005)
- Light blue (PANTONE 7542)
- Pale pink (PANTONE 5015)
- Yellow (RAL 1032)

Bicoca
LED SMD 3,2W 2700k 478lm (included)

Bicoca

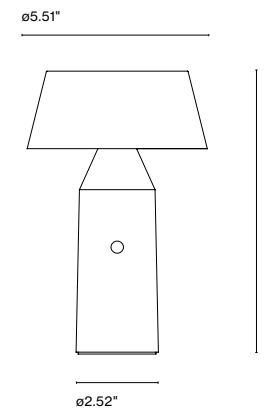

Armrest accessory

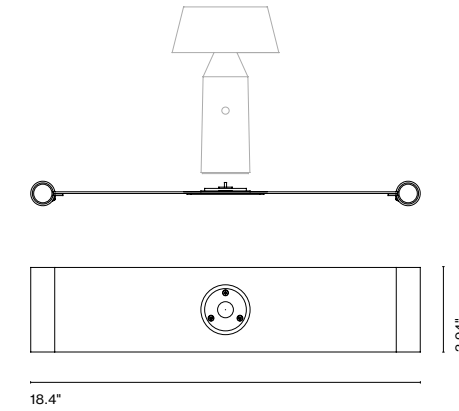

Disc accessory

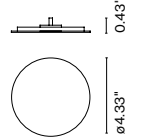

Magnet accessory



Battery life:
5 hours in peak power
10 hours in half power
20 hours in a quarter power

Battery charging time: 10h

Dimmer*

Dry locations only

Black electrical cord
* 3 positions dimmer.





#METROPOLISlikes



FollowMe Plus

The FollowMe broke molds and forged a new path in lighting: a beautiful, portable lamp to carry everywhere, a personal object of light and warmth. Three years and many accolades later and Marset is ready to launch a new version, with a larger size and greater light output: the FollowMe Plus.

FollowMe Plus complements its classic predecessor. While the original size is perfect for cozy areas, the Plus reproduces the same warmth and quality of light with greater power. This version stands out for its ability to create entire atmospheres, and is great as a table lamp, desk lamp, or even on the floor.

The FollowMe's oak handle invites you to carry it with you. Both sizes utilize LED technology and have a tilting polycarbonate screen that offers both cozy atmospheric light and direct reading light. A three-position dimmer regulates the light intensity, allowing for a continuous output of between 5 to 20 hours, and the micro USB charging cable makes charging your FollowMe quick and easy.





Rocking opal diffuser and white matte polycarbonate body. Plywood handle with natural oak veneer, brass switch and construction details. Five hours of battery life at peak performance.

White-Oak

FollowMe Plus

LED SMD 3,2W 2700k 478lm (included)

FollowMe Plus

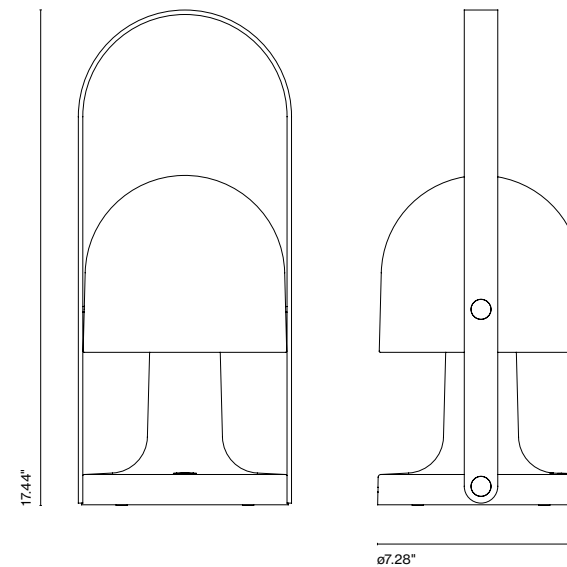

Battery life:
 5 hours in peak power
 10 hours in half power
 20 hours in a quarter power

Battery charging time: 10h

* 3 positions dimmer

Dimmer*

Dry locations only





LED-Ginger

Wood is a great ally of cozy lighting. It is a material that is hard to mold, a challenge that the LED-Ginger collection neatly resolves. The combination of sheets of wood, paper and resins pressed together under high pressure achieves a laminate that appears almost entirely flat, which discreetly lights up spaces with indirect light.

The LED-Ginger collection has been expanded over time to provide solutions to different lighting needs, and is available in pendant, table, wall, and floor lamp versions.

This year, we are adding a new, smaller suspension lamp, a portable table lamp, another version of wall lamp with a movable arm, and three different sizes of flush-mount wall lamps. The latter boast extraordinary structural simplicity, and can be combined with each other to great effect.

Thanks to a rechargeable lithium-ion battery, the new portable table version of LED-Ginger allows spaces to be lit independently with utter freedom, and with no need for wires.





Diffuser and pressed wood base of 4 mm in natural oak or wenge. Injected aluminium dissipater and lacquered black matte metal stem. Battery is located inside the base, with 5 hours of battery life at peak performance.

- Oak
- Wenge

LED-Ginger 20M
LED SMD 3,2W 1A 478lm 2700K 5V (Included)

LED-Ginger 20M

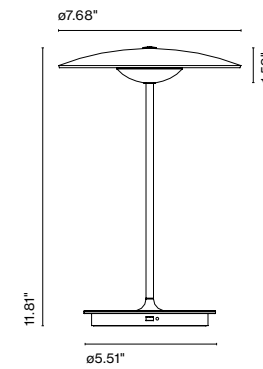

Battery life
5 hours in peak power
10 hours in half power
20 hours in a quarter power

Battery charging time: 10h

* 3 positions dimmer

Dimmer* Dry locations only

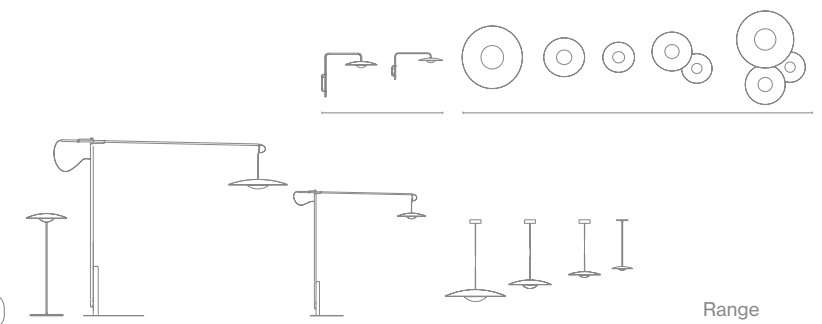

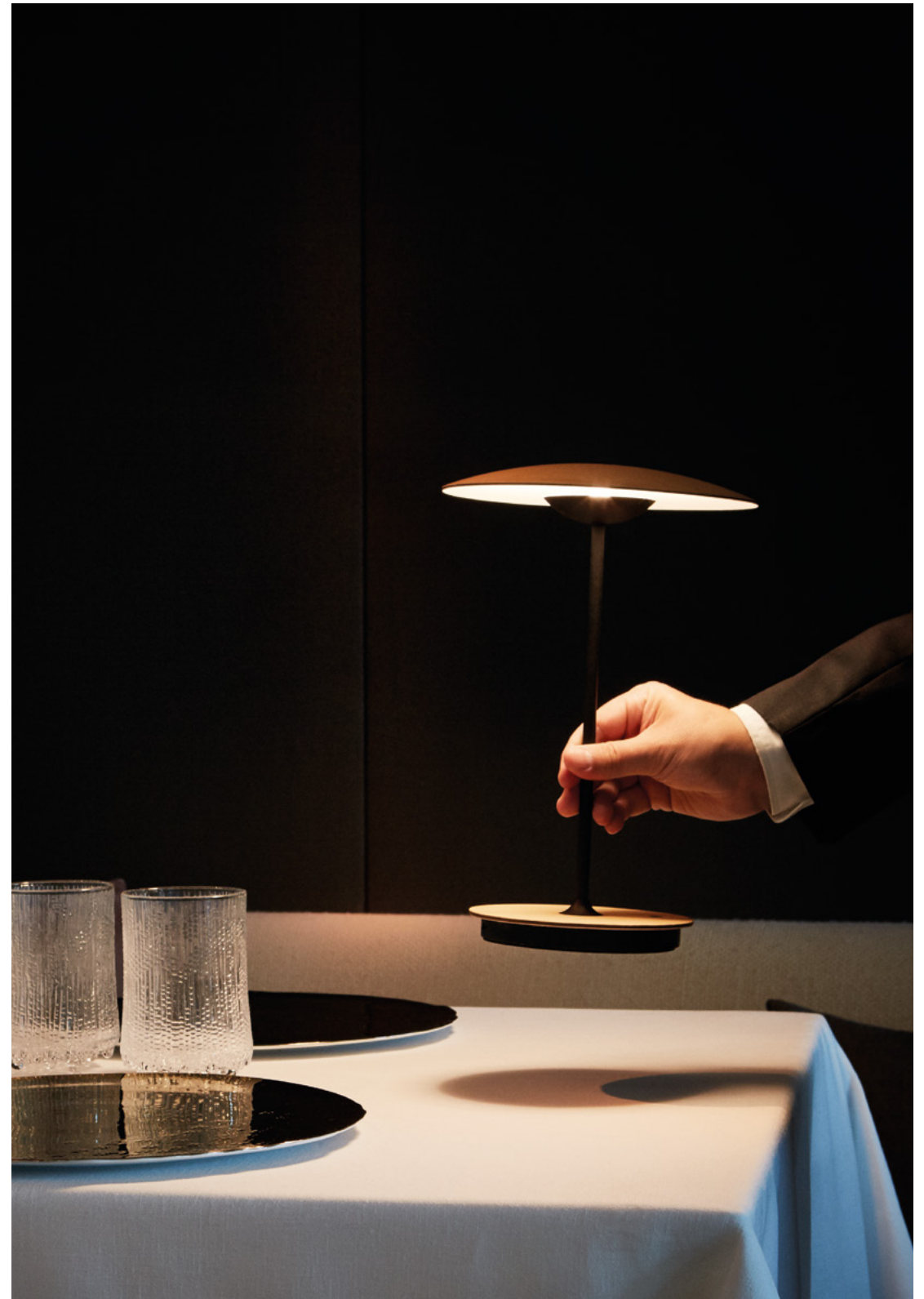



Wall

Concentric

Concentric is a visually striking lamp whether it's on or off, though turned on in the dark is when it becomes the most impressive and dynamic. The effect it promotes is almost hypnotic, because of the way the light vibrates when we view it.

Concentric's design emerges from the observation of a natural phenomenon: while on an airplane journey, the fixture's designer noticed the effect of the sunlight entering through the windows and reflecting the vibrant colors of the passengers' clothing on the curved white surface of the airplane's interior.

The Concentric collection is based on an artistic endeavour to highlight this interaction between light and the reflection of color, as each white circular panel plays with a different color on its back. In daylight, these colors are subtly perceived, but at night when the lamp is on is when they come to the fore and shine, stirring complex colored light effects.

Because of its pure symmetrical shape, Concentric plays with these reminiscences of the sun. It comes in three different sizes and three different color combinations: the Corona model with neon colors, the Major model with warm colors, and the Minor model with cool colors.



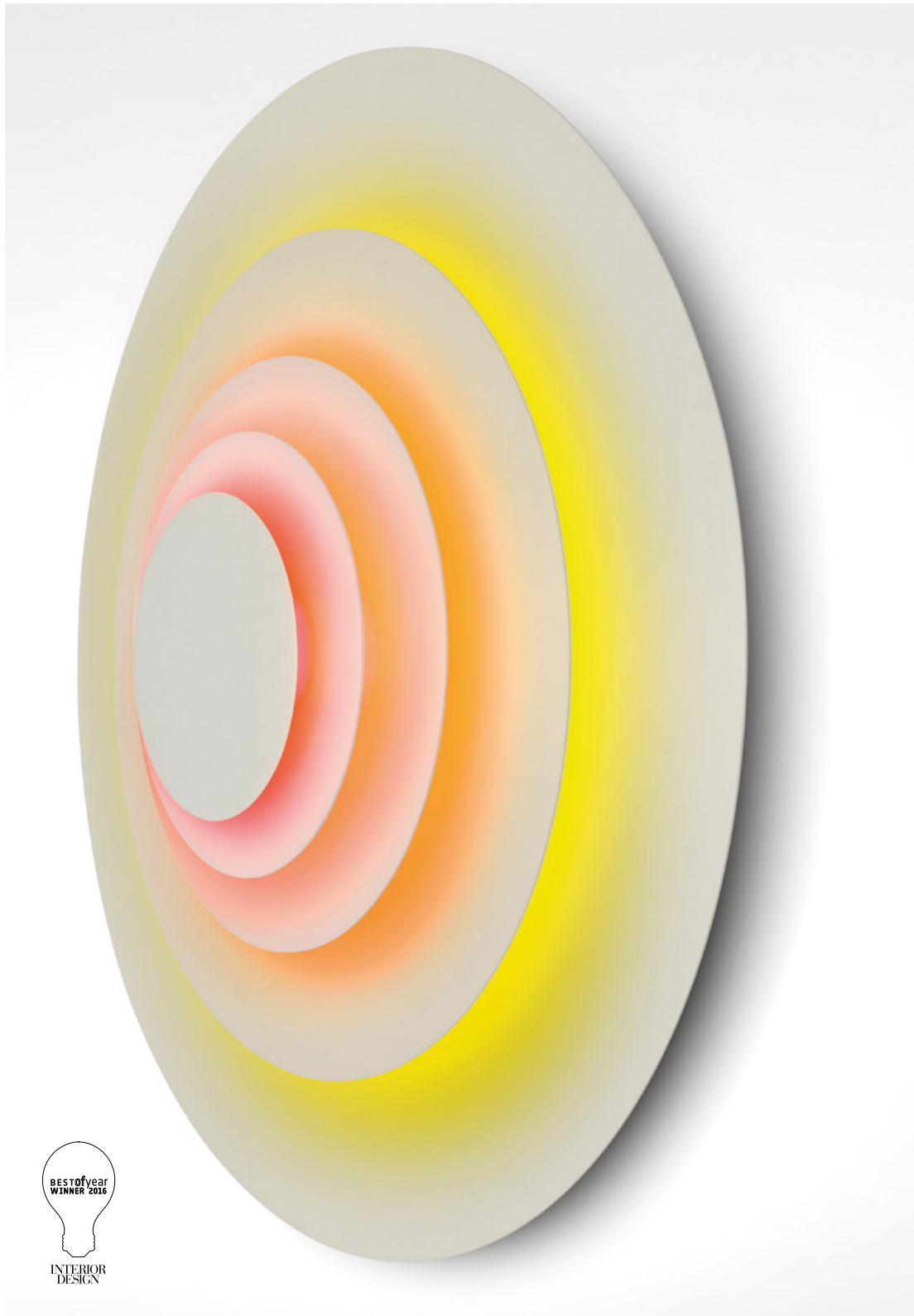

Overlapping concentric plates made of lacquered white metal, backed with colored vinyl.

- Corona**
 - Light orange
 - Gold
 - Yellow
 - Neon yellow
- Major**
 - Nut brown
 - Gold
 - Soft pink
 - Orange red
- Minor**
 - Ice blue
 - Cocoa brown
 - Mint

Concentric S / M / L
LED SMD 7,8W 700mA 2700K 1066lm (included)

Concentric S

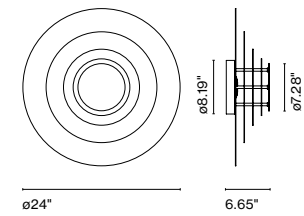

Concentric M

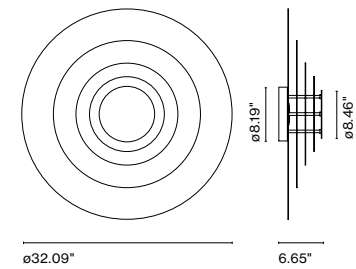

Concentric L

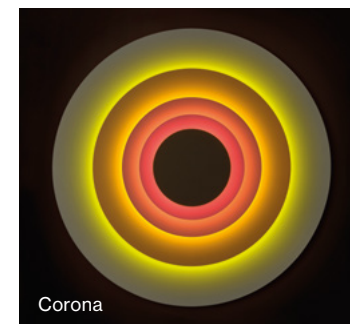
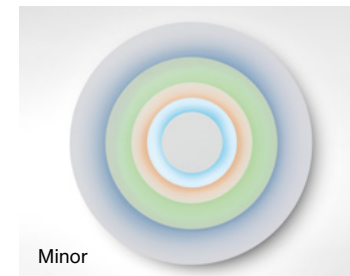
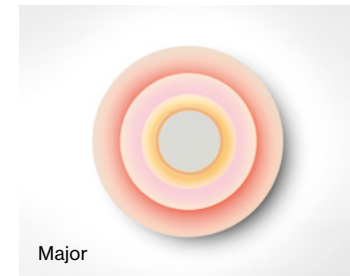
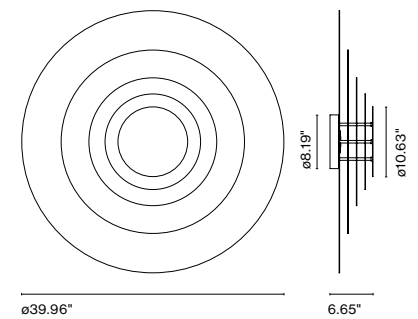

UL US Dimmable Dry locations only





Aura

A simple household item kickstarted the design process of the Aura wall lamp. This decorative lamp, which provides outstanding light while turn on but stands out beautifully while off as well, was inspired by the traditional glass carafe, a mainstay of households the world over.

The Aura follows an emotional design, because of what glass means in the collective memory, as well as a rational and contemporary design because it draws on LED technology to achieve efficiency and subtlety. The opalescent, transparent, or coloured glass of its lampshade allows the light to bathe the wall and creates a luminous effect without harshness, while also generating a point of interest in the space.

The design of the Aura is rooted in our culture. It leaves an emotional footprint, a true indication of its intention to stand the test of time and become one of those companionable objects that brings life to a house, that winks with complicity when we walk by or enjoy its light.





Polycarbonate structure and dissipater in lacquered aluminum. Lampshade in blown glass.

- ⊗ Translucent (1)
- Opal (2)
- Transparent smoked (3)
- Blue (4)
- Copper (5)
- Green (6)
- Violet (7)

Aura
LED 8,5W 2700K 830lm 220V (included)

Aura

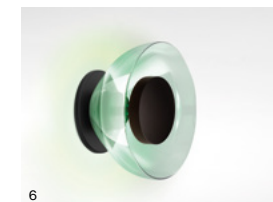
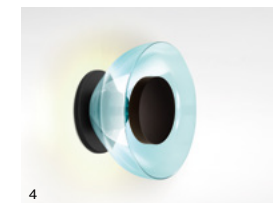
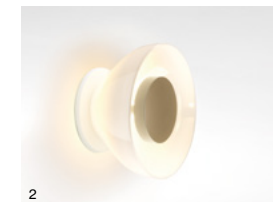
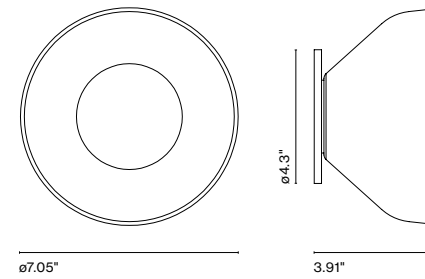

cULus ADA Dry locations only

White plate and dissipater for white shade. Black plate and dissipater for other finishes.



N°8

The N°8 reading lamp fulfils all the necessary criteria for perfect operation: efficient light, easy handling, durability, and beauty. It was designed specifically to respond to each of these requirements, resulting in a “well-rounded” fixture that fulfills its mission perfectly.

The wooden sphere of the N°8’s lampshade is handcrafted to make each lamp unique. Its smooth texture has the quality and feel of a billiard ball, while its flexible arm, covered in braided fabric, is a mainstay that improves its look without sacrificing its efficacy.

The N°8 was designed to be placed at the head of a bed and add comfort to the bedroom, a place dedicated to restfulness, where a good book is always healthier than a sleeping pill.





Plate made of lacquered black metal with a flexible brass arm covered in black braided fabric. Turned wooden diffuser in natural oak or wenge. Integrated rocker switch at the base of the fixture.

Structure

● Black

Diffuser

● Oak

● Wenge

N°8

LED 3W 700mA 2700K 150lm (included)

N°8

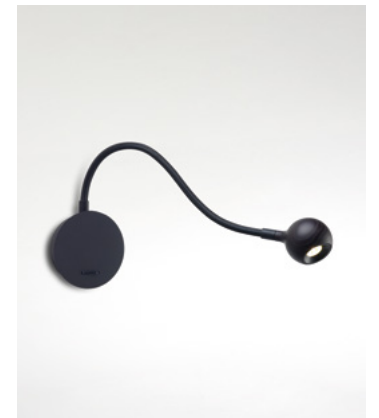
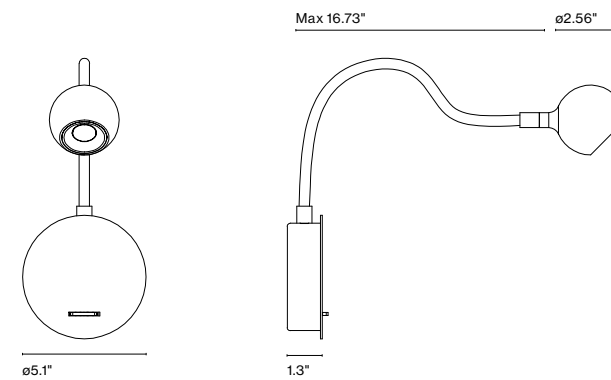



LED-Ginger

Wood is a great ally of cozy lighting. It is a material that is hard to mold, a challenge that the LED-Ginger collection neatly resolves. The combination of sheets of wood, paper and resins pressed together under high pressure achieves a laminate that appears almost entirely flat, which discreetly lights up spaces with indirect light.

The LED-Ginger collection has been expanded over time to provide solutions to different lighting needs, and is available in pendant, table, wall, and floor lamp versions.

This year, we are adding a new, smaller suspension lamp, a portable table lamp, another version of wall lamp with a movable arm, and three different sizes of flush-mount wall lamps. The latter boast extraordinary structural simplicity, and can be combined with each other to great effect.

The new wall lamps, which are formally extremely simple, are manufactured in three sizes. They also come in a set of two or three pieces to meet the qualities and needs of the space. The inside of the lampshade is offered not only in white but also in an oak and wenge finish, yielding different shades of light.



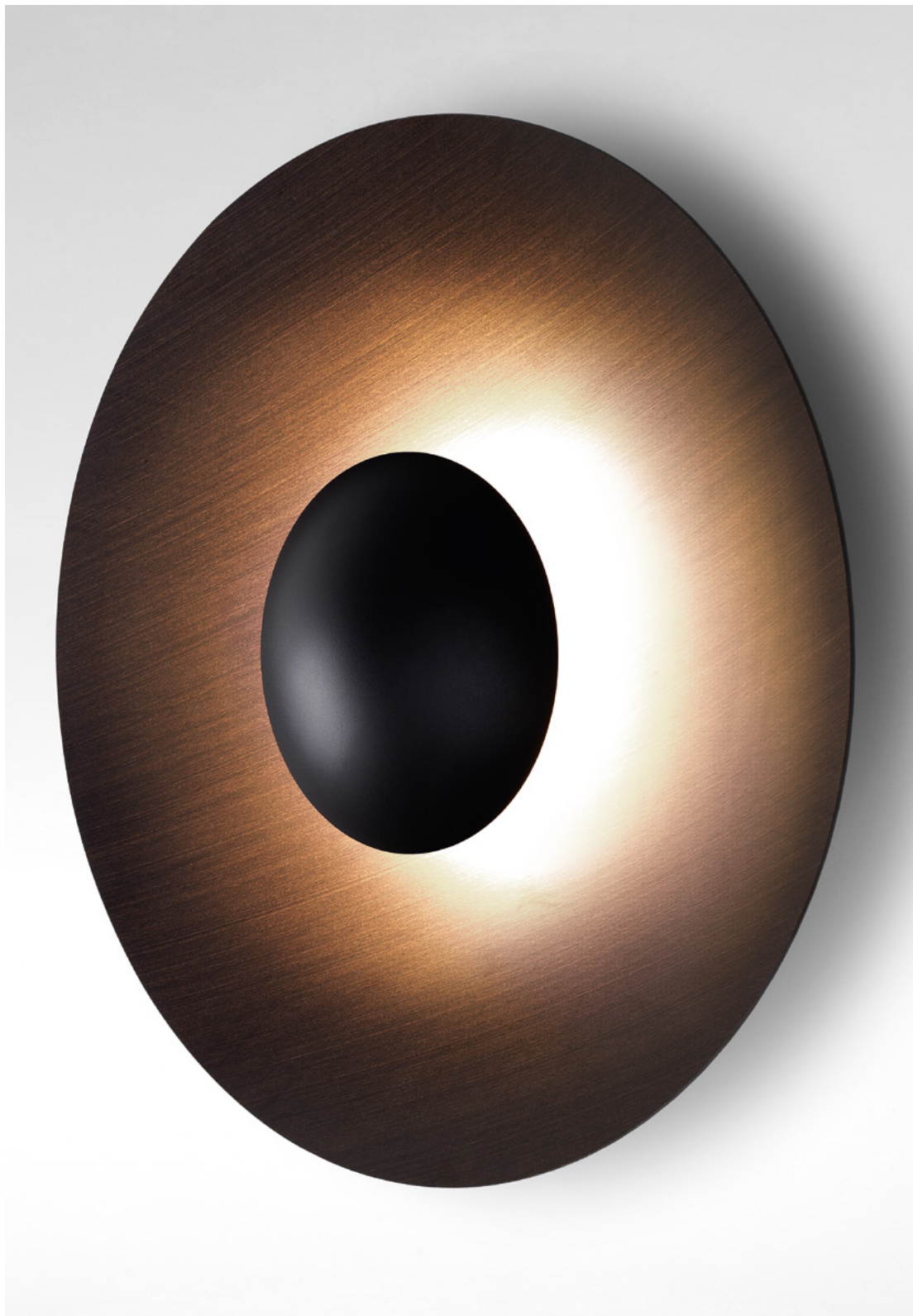

Pressed wood diffuser of 0.16 inches in natural oak or wenge. Injected and lacquered black metal matte aluminum dissipater.

- Oak-White
- Wenge-White
- Oak-Oak
- Wenge-Wenge

Ginger 32 C
LED SMD 7,8W 700mA 2700K 1066lm
(included)

Ginger 42 C
LED SMD 15,4W 700mA 2700K 2130lm
(included)

Ginger 60 C
LED SMD 20,8W 700mA 2700K 3023lm
(included)

Accessory C2
LED SMD 23,2W 700mA 2700K
3196lm (included)

Accessory C3
LED SMD 44W 700mA 2700K 6219lm
(included)

LED-Ginger 32 C

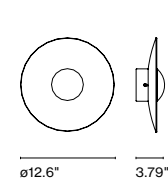

LED-Ginger 42 C

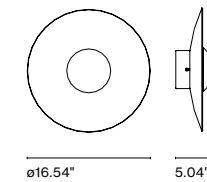

LED-Ginger 60 C

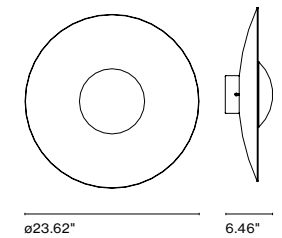

Accessory C2

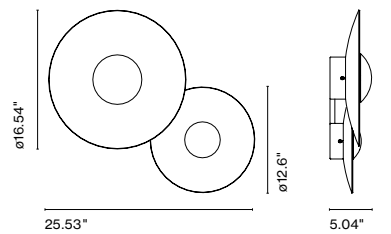

Accessory C3

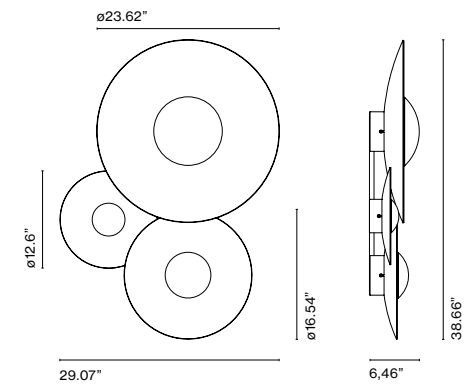

Dry locations only



Dimmable

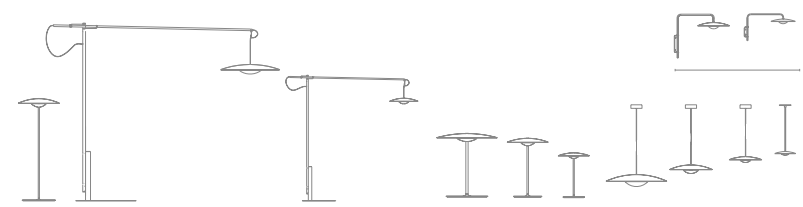

Range



Pressed wood diffuser of 0.16 inches in natural oak or wenge. Injected aluminum dissipater and metal stem in lacquered black matte.

- Oak
- Wenge

LED-Ginger 20 A
LED SMD 4W 350mA 2700K 546lm (included)

LED-Ginger 20 A (Plug-in)

LED-Ginger 20 A (Hardwired)

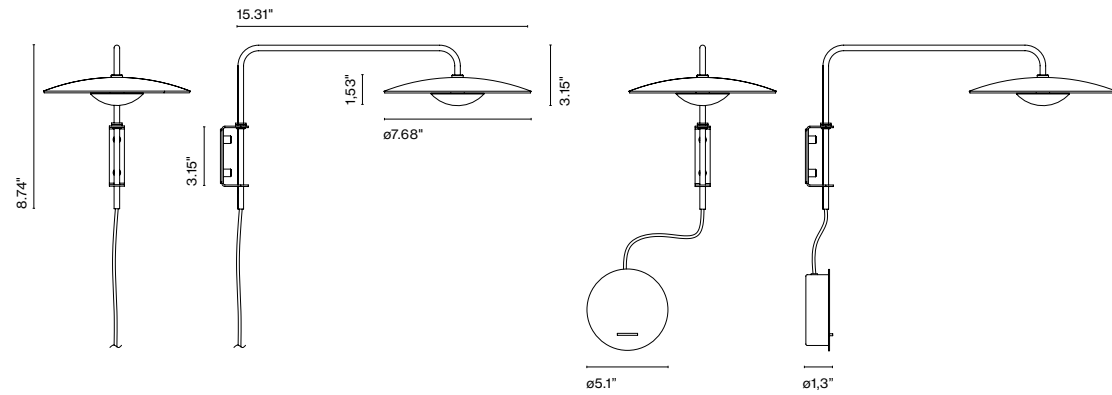

**Only for the Plug-in wall version: inline motion sensor dimmer

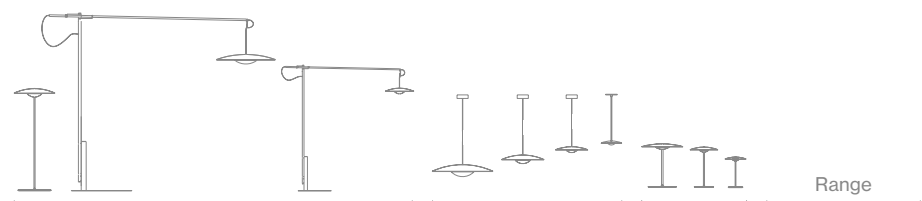

Ceiling



Djembé

Like the echo of a drum, the Djembé collection is designed for repetition, creating musical compositions of light on the ceiling. A bell-shaped ceiling fixture with an exposed interior, Djembé is available in a numerous sizes and bright, airy colors that can be used individually or combined to create a brilliant statement piece.

Using a rotomolding technique allowed the designer, Joan Gaspar, to design a fixture with vastly different interiors and exteriors: its outside recalls the texture of a stone, giving off a perception of great weight, emphasized by its volume. In the spacious interior you'll find a smooth, white space perfect for the reflection of light.

Djembé is a lamp designed for use in public spaces that seeks to bring beauty and an unbeatable quality of light. A separate accessory allows for the installation of sound-proofing panels.

Shade made of bi-injected rotary moulded polyethylene: stone texture on the outer part and smooth satin white on the inner part of the fixture. Diffuser in lacquered grey aluminum.

- White
- Grey (RAL 7022)
- Red
- Sky blue

Djembé C 42
LED SMD 11,7W 700mA 2700K 2040lm (included)

Djembé C 65, Djembé 2 C
LED SMD 20,8W 700mA 2700K 3023lm (included)

Djembé C 42.13

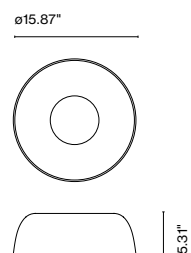

Djembé C 42.21

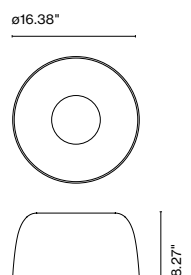

Djembé C 42.28

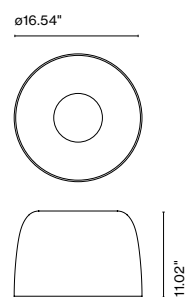

Djembé C 65.23

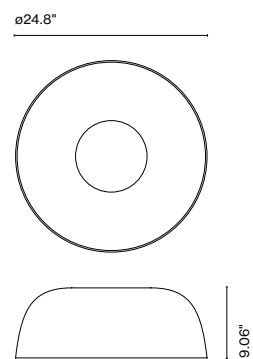

Djembé C 65.35

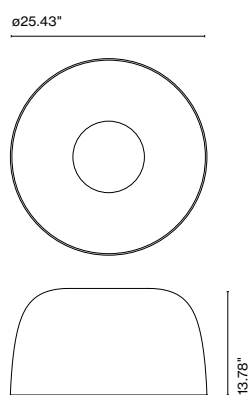

Djembé C 65.45

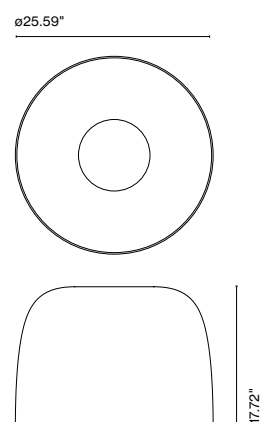

Djembé 2 C 65.36

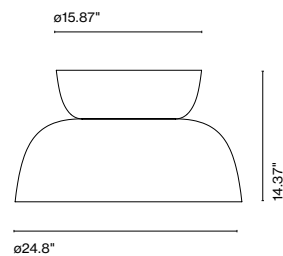

Djembé 2 C 65.48

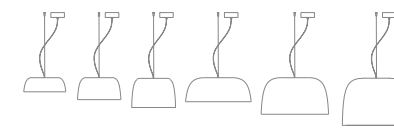
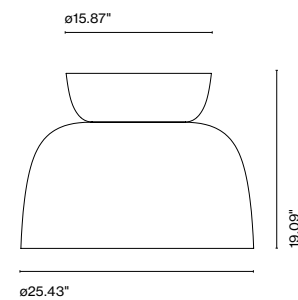

Range



Double compositions

Triple compositions

Accessory C2 Djembé 65

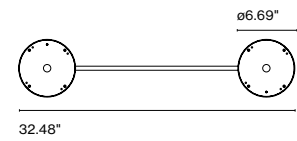

Accessory C2 Djembé 42

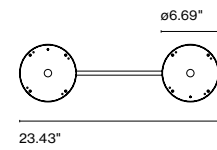

Accessory C3 Djembé 65

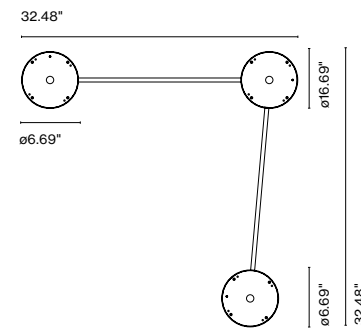

Accessory C3 Djembé 42

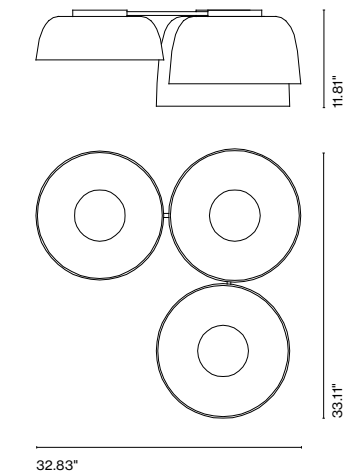
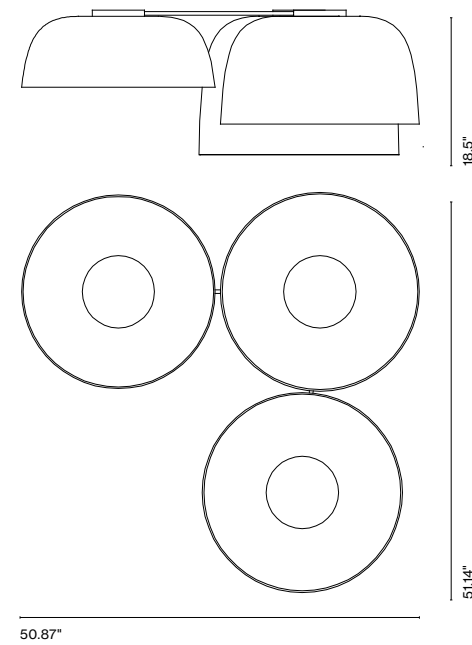
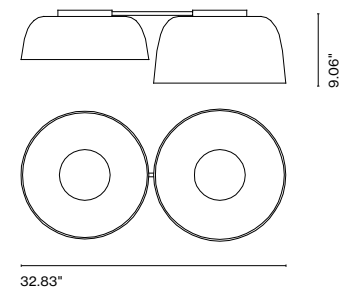
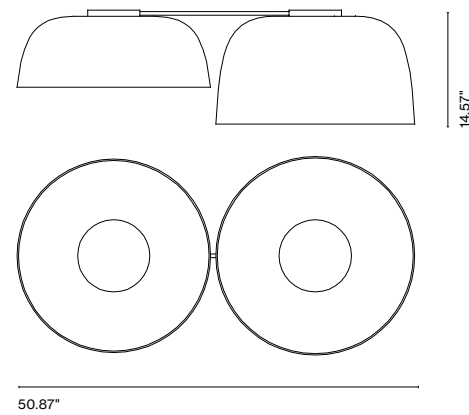
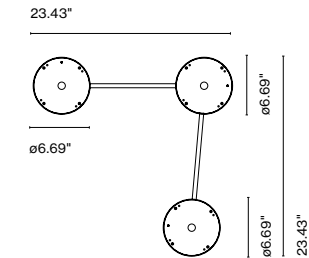



Sun

The concept of Sun is inspired by the early hours dawn, when the light of the sun plays along the horizon as it begins to appear. The Yonoh studio played with superimposing materials to achieve this effect, creating a light with a luminous glow that is capable of transporting us to that precise moment.

The light that emanates from Sun creates a very special atmosphere, capturing our eyes and soothing our souls. It is a presence that brings personality and character to the space around it. The fixture's design does not forget that its prominent place in the space necessitates a certain formal balance: it is simultaneously prominent yet understated, a point of interest that doesn't steal the limelight.

A metal case and concave polycarbonate dish surround the LED light source, nestled in a blown-glass sphere. Each of Sun's different materials reflects the light in its own way, much as what happens at the exact moment when the night's darkness gives way to the light.



Lacquered iron structure in white or graphite. Diffuser made of thermoformed opal methacrylate, with another diffuser in opal blown glass placed off-centre.

- White
- Graphite

Sun 26
LED 13,8W 700mA 2700K 1890lm (included)

Sun 40
LED 25,9W 700mA 2700K 3688lm (included)

Sun 60
LED 33,6W 700mA 2700K 5176lm (included)

Sun 26

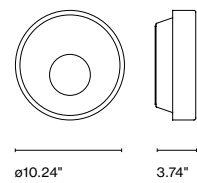

Sun 40

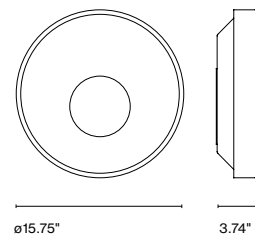

Sun 60

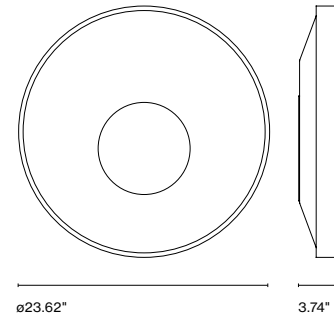

ADA

Dry locations only





Outdoor

Jaima

Through the language of textiles, Joan Gaspar has designed a light of flexible, ductile materials that sifts the light as readily as it moves with the wind. In the Jaima collection, the light is the shade and weaver of emotions.

This new collection takes its name from the Bedouin tents of North Africa, and is inspired by their varied fabrics and forms. The textile shade is available in three sizes and four different colors, with an off-white interior to optimize the quality of the downward light.

The shades can be combined with two versatile stands to make various sizes of adjustable, rotating floor lamps; the fixture can also be affixed directly to the floor or wall, and the shades can be hung independently as pendants.



Shade made of textilene with the inner part always in white. Stainless steel structure in lacquered grey.

- Blue
- Beige
- Grey
- Green

Jaima 43 IP65

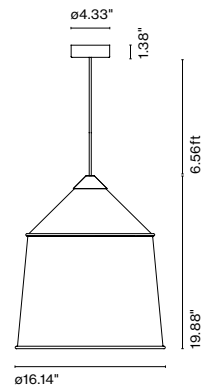

Jaima 54 IP65

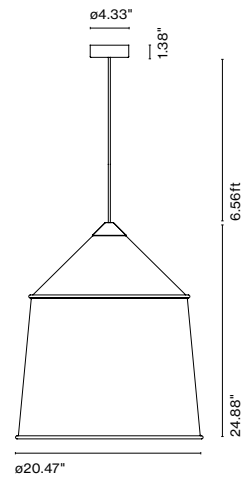

Jaima 71 IP65

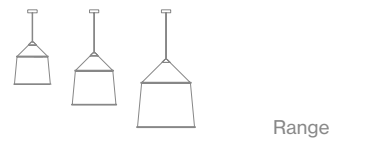
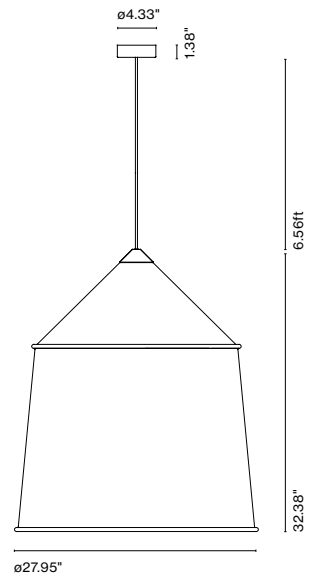

Suitable for wet locations

Dimmable Black electrical cord





Jaima P207

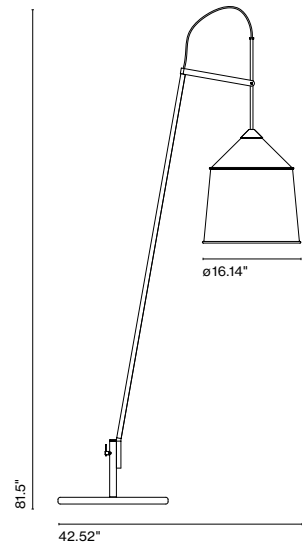

Jaima P307 extensible with shade 54

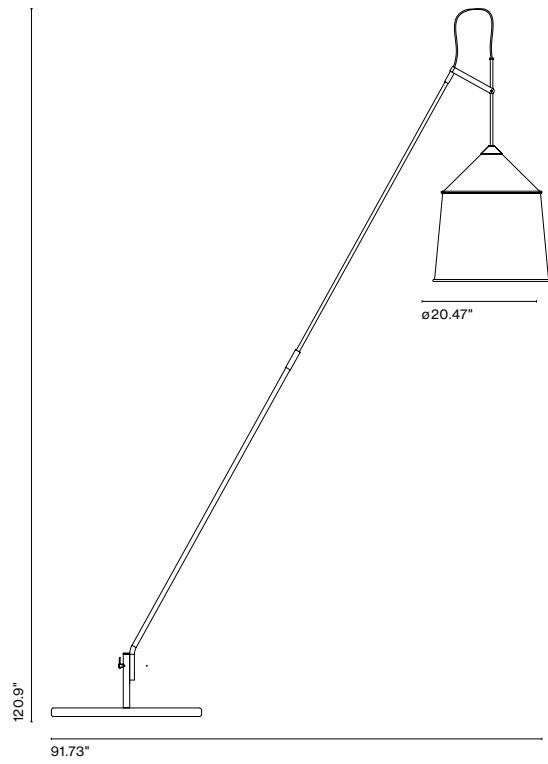

Jaima P307 extensible with shade 71

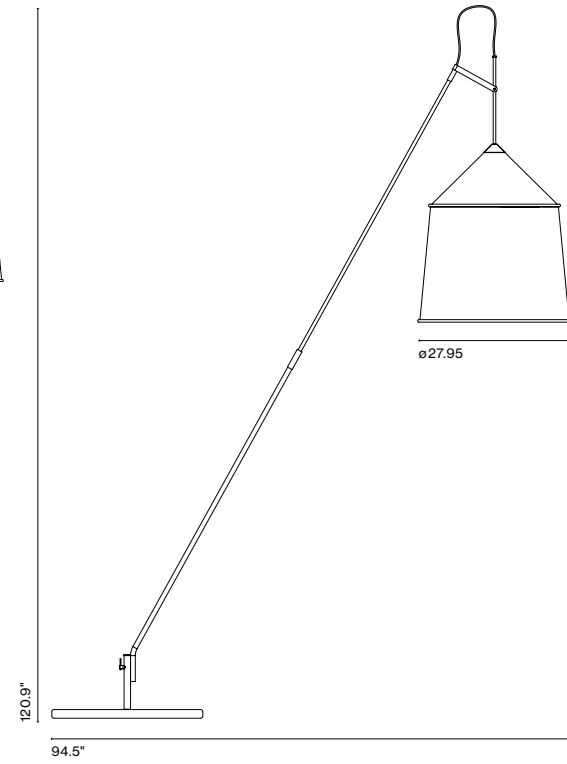

Base

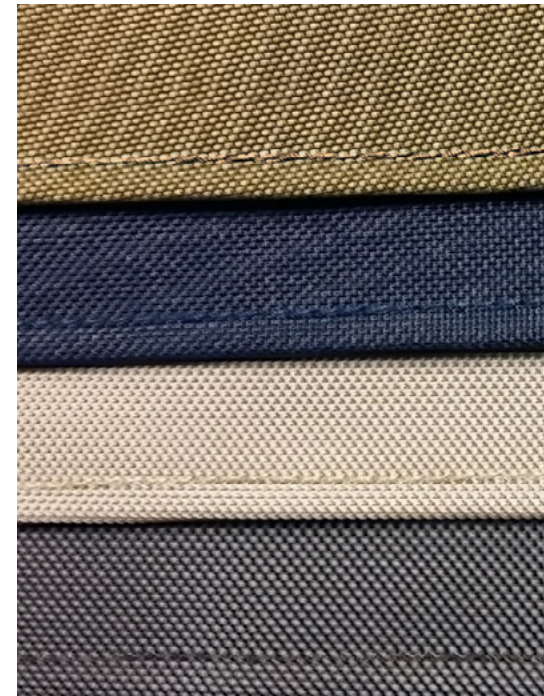

Shade finishes



Floor support

Dimmable

Black electrical cord

Range of positions

Jaima P207

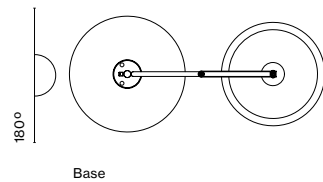
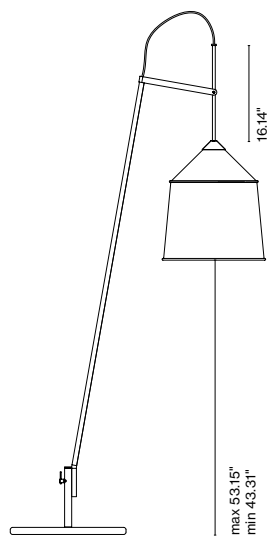

Jaima P307 extensible with shade 71

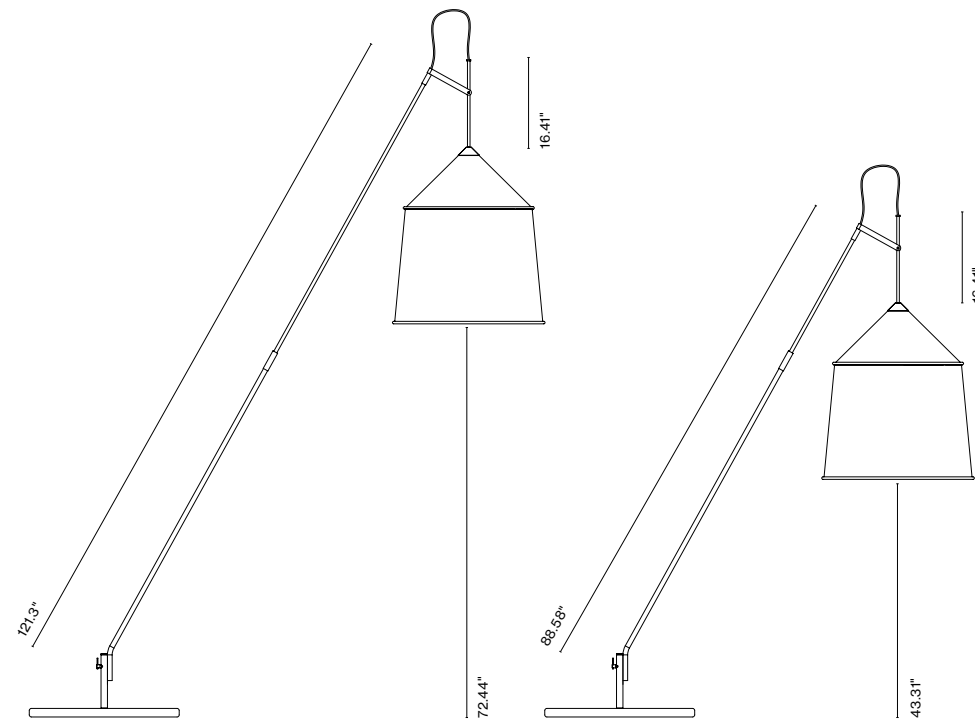

Jaima P307 extensible with shade 54

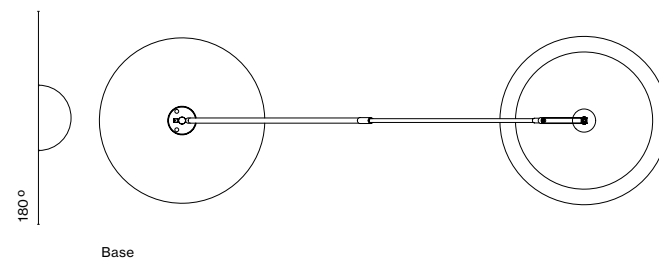
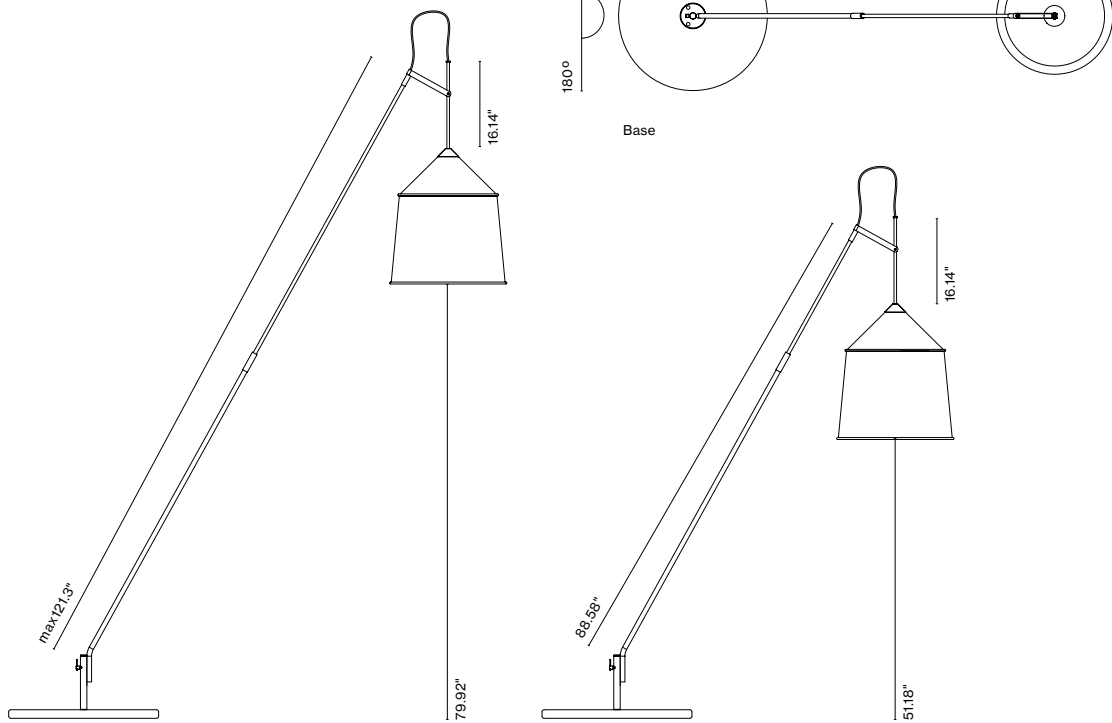





Soho

Soho is presented as a statement, in recognition of the merits of the lamps traditionally used in markets, taverns and cafeterias. After studying different volumes, proportions and materials, new uses and lighting effects have emerged.

The use of rotation-moulded polyethylene allows us to easily offer this fixture in a wide range of sizes. Whereas before the Soho collection offered diameters of 22" and 44", now it's also available in a smaller size, measuring just 15".

This new size is more appropriate for smaller spaces, and increases the overall versatility of this fixture. This new size is also available as a new outdoor floor lamp, thus completing the collection.

The existing color range—black, grey and translucent white—is now joined by two new tones: sand and sky blue.





Shade in rotary moulded polyethylene. Methacrylate opal diffuser. Metal structure lacquered in black with stainless anti-oxidant cataphoresis treatment for outdoor. Cable support for the wall version.

- White
- Stone grey
- Black
- Sand
- Sky blue

Soho 38 IP44 LED / Soho 38 A LED
LED SMD 13,2W 700mA 2700K 1931lm

Soho 38 P LED
LED SMD 7,8W 700mA 2700K 1066lm

Soho 38 P LED

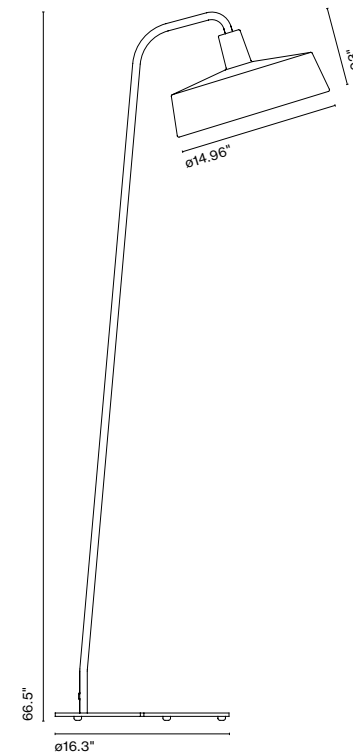

Soho 38 IP44 LED

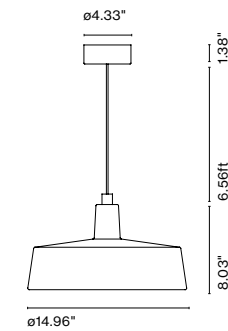

Soho 38 A LED

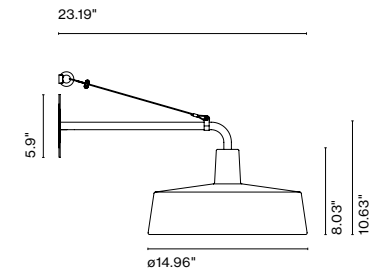

Black electrical cord
**All outdoor models cULus certified with the exception of the Soho P floor lamp

Suitable for wet locations

cULus** Dimmable

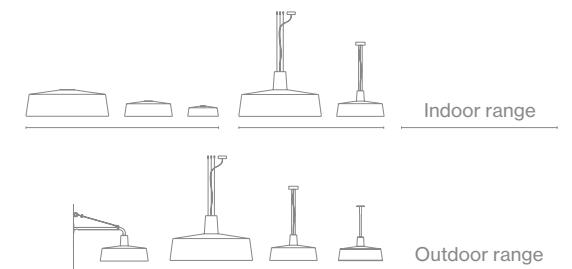



Symbols

Dry locations only

A fixture for indoor use, where it will not be exposed to excessive moisture and water.

Suitable for wet locations

A fixture suitable for outdoor locations that receive direct contact with rain, snow or excessive moisture.

Dimmer

Dimmer on the unit

Dimmable

Product which can be dimmed.

Certifications



Product with cULus mark indicates compliance with U.S and Canadian safety standards, as set by Underwriters.



Products under approval process. Please check our website for updated information.

ADA

ADA Compliant Wall Lighting: Objects projecting from walls with their leading edges between 27 inches and 80 inches (2' 4" to 6' 8") above the finished floor shall protrude no more than four inches into walks, halls, corridors, passageways or aisles.

Coordination

Isabel Valle

Concept, graphic design & art direction

Folch

Creative direction in production & printing

Artifact

Photography

Alexis Taulé
Leo García Méndez
Mariluz Vidal
Marçal Vaquer

Cover illustration

Tiago Majuelos

Acknowledgments

Gustavo Gili Editorial
Hotel Alma
Hotel Mandarin Barcelona
Hotel Ohla Eixample
Minim
Narcís Barceló
Punto Consultintg
Wallpaper magazine

Printed in August 2017

Copyright © 2017 Marset.
All rights reserved





Joan Gaspar with the Djembé





Xavier Mañosa with the Pu-erh







Christophe Mathieu with the Bicoca



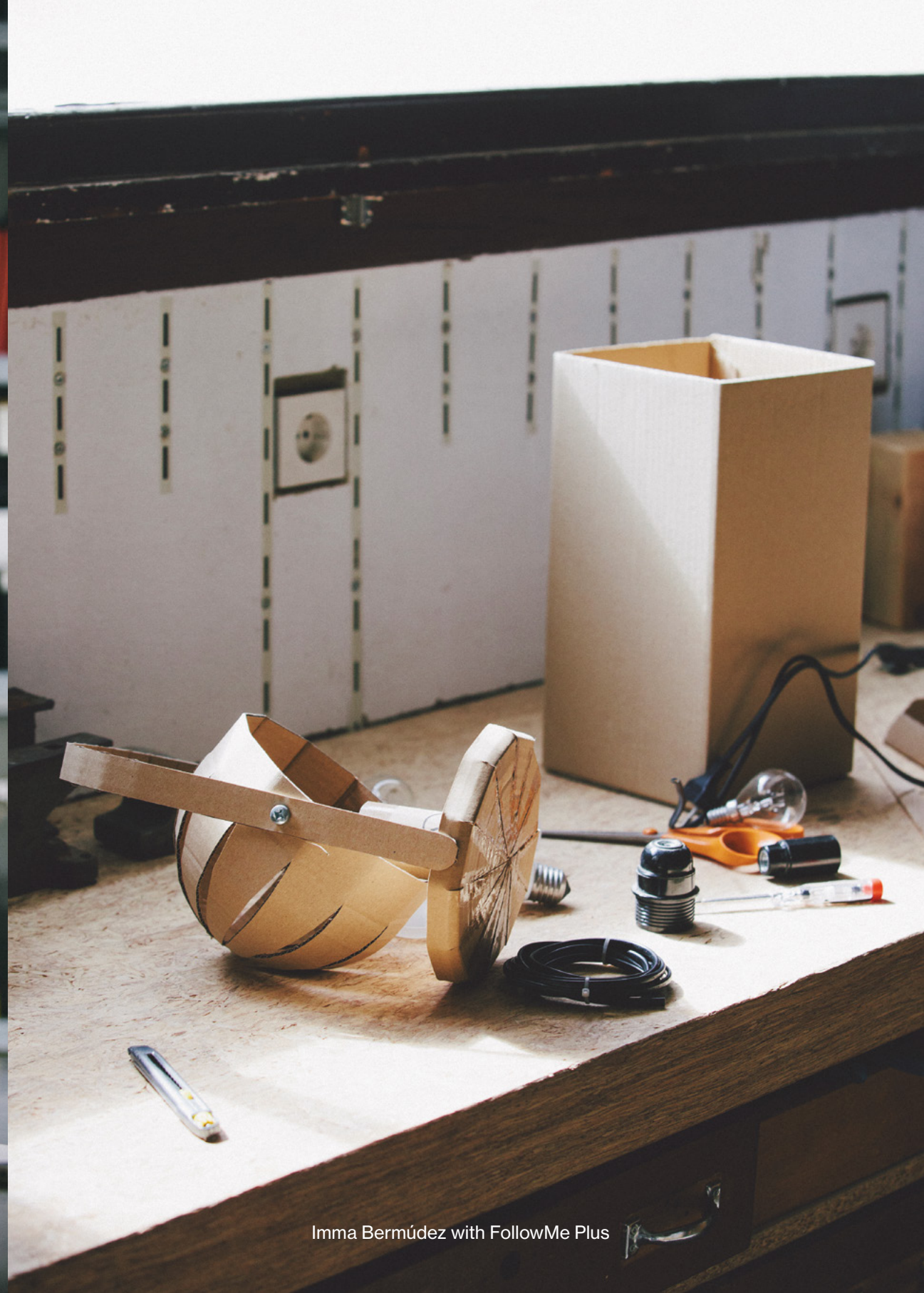



Technical drawing and specifications for a lamp design.

ITEM	DESCRIPTION	QTY	UNIT
1	WOODEN FRAME	1	PC
2	WHITE SHADE	1	PC
3	BASE	1	PC

SCALE: 1/8"
FOLLOW ME 1



Christophe Mathieu with the Piola



PIOLA

Proposta de disseny i solucions
SOLUCIÓ PIOLA?

La planta baixa està
dissenyada a partir
de la planta que s'ha
presentat.

La planta baixa
està dissenyada
per tenir una
cobertura de
la planta baixa
amb la planta
que s'ha presentat.



Joan Gaspar with the Jaima





Ramírez i Carrillo with the Copérnica





